



## Our products

CONTACTS

Lined pipes

Spacers

Elbows

Tees

Crosses

Instrument-Tees

Reducers

Valves

Blind flanges

Expansion joints

Nozzle liners and dip pipes

Hoses

Special parts

Accessories

TECHNICAL SPECIFICATIONS



# Innovation and quality. BAUM.

BAUM KUNSTSTOFFE GMBH, located in Birkenfeld (Germany), manufactures the complete range of PTFE-lined piping components - according to both DIN and ANSI standards.

For more than 25 years we have operated a family-owned and run business which is independent and enjoys flexibility resulting from quick decisions. With excellent products, global references and several subsidiaries around the world, we are a strong and reliable partner.

What does BAUM offer to you?

First priority: QUALITY

We offer long-term safety and security to chemical manufacturers:

- certification according DIN EN ISO 9001 : 2008
- qualification according Pressure Equipment Directive (PED) 97/23/EC
- FDA-conformity of the lining

Urgent solutions to challenges: FLEXIBILITY

We react quickly to individual requirements:

- quick decisions and a motivated team
- state of the art technical production equipment , including internal metal fabrication

Individual piping systems: INDIVIDUALITY

For some issues in plant manufacturing there are no standard solutions. We thrive to offer solutions to special or difficult applications. We are able to achieve this via:

- vertical integration of our production
- in-house construction
- independence from subcontractors.

The BAUM-Team

## Your contacts at BAUM!



**Frank Escher**  
Sales Director  
Phone +49. 7082. 94 36 - 60  
fescher@baumkunststoffe.com



**Michael Schmauß**  
Sales South&East. Germany+Australia  
Phone +49. 7082. 94 36 - 15  
mschmauss@baumkunststoffe.com

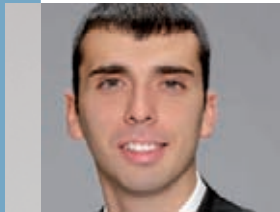

**Igor Petrov**  
Sales Eastern Europe  
Phone +49. 7082. 94 36 - 19  
ipetrov@baumkunststoffe.com



**Peter Schardt**  
Service Center Waldernbach  
Sales Germany and Service  
Phone +49. 6479. 91 18 46  
pschardt@baumkunststoffe.com

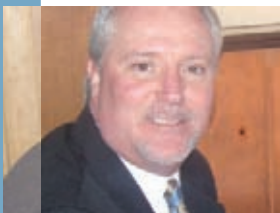

**Jeff Farrell**  
BAUM AMERICA CORP.  
Sales USA/Canada  
Phone +1. 716. 694 1063  
jfarrell@natechsales.com



**Gary Morrison Jr.**  
BAUM AMERICA CORP.  
Sales USA/Canada  
Tel. +1. 713. 539. 4493  
g2morrison@natechsales.com



**Kerstin Lausch**  
Sales Western Europe  
Phone +49. 7082. 94 36 - 16  
klausch@baumkunststoffe.com

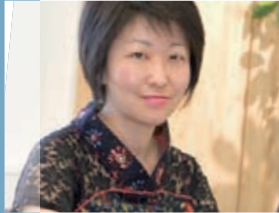

**Lin Lin**  
Sales Asia  
Phone +49. 7082. 94 36 - 61  
llin@baumkunststoffe.com



**Claudia Drews**  
Inside Sales  
Phone +49. 7082. 94 36 - 63  
cdrews@baumkunststoffe.com

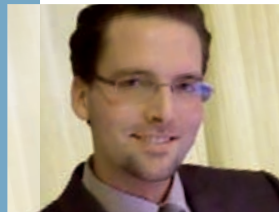

**Christian Schardt**  
Service Center Waldernbach  
Sales Germany and Service  
Phone +49. 6476. 4190234  
cschardt@baumkunststoffe.com



**Jian Xu**  
BAUM FLUORPLASTIC Co.Ltd.  
Sales China  
Phone +86. 21. 57 21 97 98  
jxu@baum-fluoroplastics.com



**Gary Morrison**  
BAUM AMERICA CORP.  
Sales USA/Canada  
Phone +1. 304. 755-2571  
gmorrison@natechsales.com

## Lined pipes



## Pipes (PN 10)

Our pipes are lined, totally stainless, with paste-extruded PTFE and tested fully automatic. We produce pipes up to a length of 6 metres.

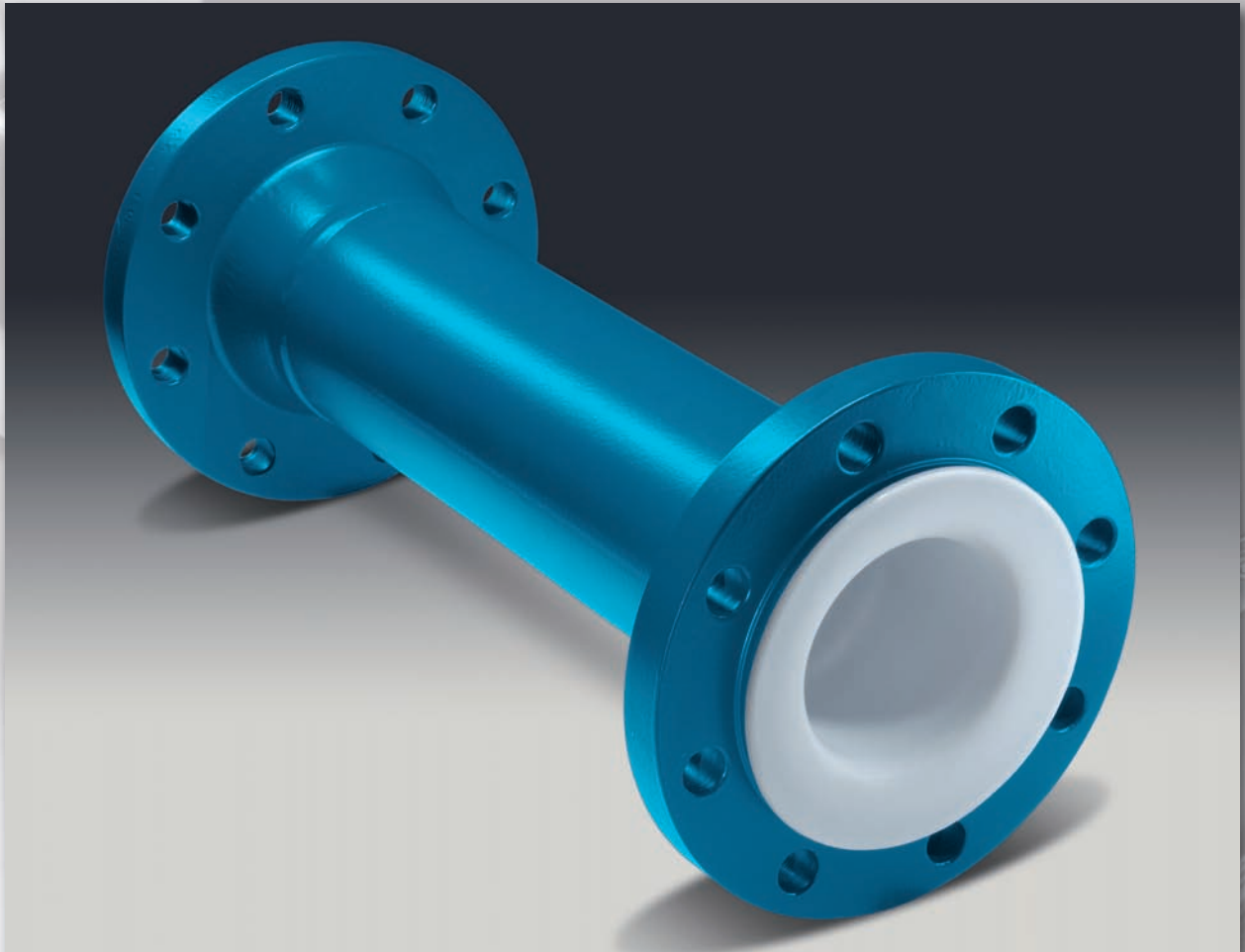

# Lined Pipes (PN 10)

Lining material:

- PTFE (virgin or conductive)
- PP (up to diameter nominal DN 300)

Different lining thicknesses on request.

Flange design:

- fix-loose
- fix-fix
- loose-loose

Other pressure rates:

- PN 16
- PN 25
- PN 40

Material: carbon steel and stainless steel

Special features: earthing studs, earthing lugs, flange stopper, field flaring pipes, final painting.





DN	L (mm)		d <sub>1</sub> (mm)	d <sub>4</sub> (mm)	K (mm)	a <sub>1</sub> (mm)	a <sub>2</sub> (mm)	Screws	Weights	
	max.	min.							Pipe (ca. kg/m)	Pair of flanges (ca. kg)
15	6000	65	21,3	45	65	19,0	29,0	4 x M 12	1,2	1,5
20	6000	75	26,9	58	75	21,0	33,0	4 x M 12	1,6	2,0
25	6000	75	33,7	68	85	21,0	33,0	4 x M 12	2,5	2,5
32	6000	80	42,4	78	100	21,0	35,0	4 x M 16	3,4	3,6
40	6000	80	48,3	88	110	21,0	35,0	4 x M 16	4,5	4,2
50	6000	90	60,3	102	125	21,0	38,0	4 x M 16	5,8	5,5
65	6000	90	76,1	122	145	21,0	39,0	4 x M 16	7,1	6,6
80	6000	100	88,9	138	160	23,0	39,0	8 x M 16	10,0	8,3
100	6000	100	114,3	158	180	23,0	43,0	8 x M 16	14,0	9,9
125	6000	100	139,7	188	210	26,5	44,5	8 x M 16	17,5	13,2
150	6000	100	168,3	212	240	27,0	49,0	8 x M 20	23,5	16,0
200	6000	120	219,1	268	295	29,0	49,0	8 x M 20	39,0	23,0
250	4000	130	273,0	320	350	31,0	53,0	12 x M 20	55,5	31,0
300	3000	130	323,9	370	400	31,0	53,0	12 x M 20	74,0	39,0
350	3000	130	355,6	430	460	31,0	55,0	16 x M 20	85,0	52,0
400	3000	130	406,4	482	515	31,0	61,0	16 x M 24	102,0	67,0
450	3000	130	457,0	532	565	33,0	65,0	20 x M 24	130,0	85,0
500	3000	140	508,0	585	585	33,0	69,0	20 x M 24	155,0	90,0

DN	Standard	Lining thickness (mm)	Possible vacuum		
			23°C	100°C	230°C
25	●	3	Full	Full	Full
		4	Full	Full	Full
40	●	3	Full	Full	Full
		4	Full	Full	Full
50	●	3	Full	Full	Full
		4	Full	Full	Full
80	●	3	Full	Full	Full
		4	Full	Full	Full
100	●	3	Full	Full	Full
		4,5	Full	Full	Full
150	●	5	Full	Full	Full
		6	Full	Full	Full
200	●	5	Full	Full	Full
		6	Full	Full	Full
250	●	5	Full	Full	Full
		7,5	Full	Full	Full
300	●	5	Full	Full	Full
		7,5	Full	Full	Full

Standard lengths available from stock:  
flange design fix-loose

- L = Total length
- d<sub>1</sub> = External diameter of the pipe
- d<sub>4</sub> = Flaring diameter
- K = Bolt circle
- a<sub>1</sub> = Length with fixed flange (standard lining)
- a<sub>2</sub> = Length with loose flange (standard lining)

### Vacuum resistance:

-  = full vacuum
-  = limited vacuum
-  = no vacuum

Please refer to the next diameter nominal if your diameter nominal is not listed.

## Spacers



## Spacers Form F (PN 10)

Flexible up to the last millimetre! For lengths up to 20 mm we recommend spacers Form F made of solid PTFE.

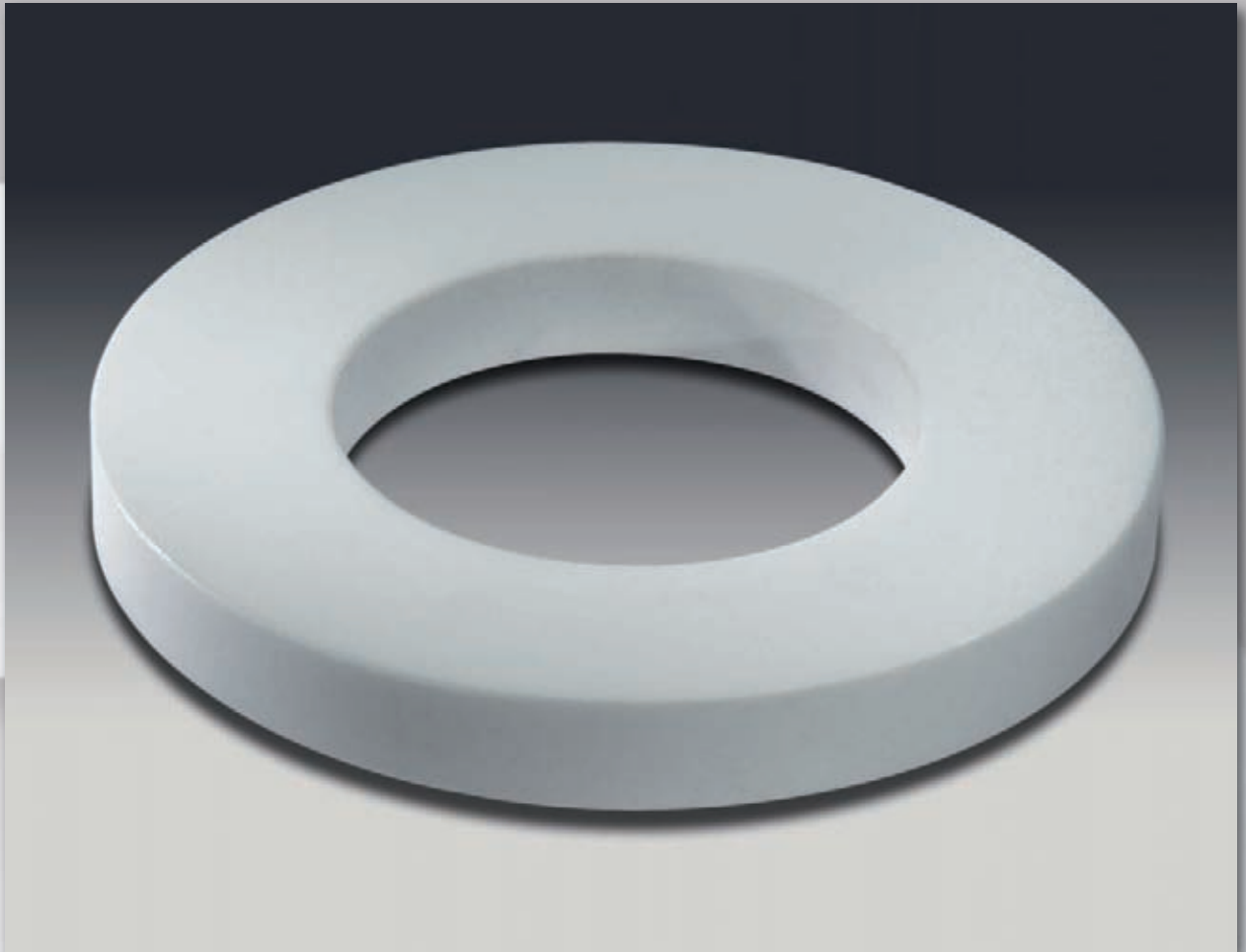



# Spacers Form F (PN 10)

Material:

- PTFE (virgin or conductive)
- PP (up to diameter nominal DN 300)

Other pressure rates:

- PN 16
- PN 25
- PN 40

Special features:

- with reinforcement ring
- filled PTFE

Spacers Form F are also available as **inclined spacers** with various degrees.

Form F



DN	L (mm)			d <sub>1</sub> (mm)	d <sub>2</sub> (mm)	d <sub>8</sub> (mm)	Weight (ca. kg/m)
	min.		max.				
15	10	---	15	21,3	14	50	0,10
20	10	15	20	26,9	16	60	0,10
25	10	15	20	33,7	22	70	0,20
32	10	15	20	42,4	31	82	0,25
40	10	15	20	48,3	37	92	0,30
50	10	15	20	60,3	48	107	0,40
65	10	15	20	76,1	64	127	0,50
80	10	15	20	88,9	76	142	0,60
100	10	15	20	114,3	101	162	0,75
125	10	15	20	139,7	125	192	1,10
150	10	15	20	168,3	153	218	1,40
200	10	15	20	219,1	201	273	2,00
250	10	15	20	273,0	254	328	3,20
300	10	15	20	323,9	303	378	4,00
350	10	15	25	355,6	333	438	4,50
400	10	15	25	406,4	382	488	5,20
450	10	15	25	457,0	430	540	6,10
500	10	15	25	508,0	480	594	7,20

Standard lengths available from stock.



























L = Total length

d<sub>1</sub> = External diameter of the pipe



d<sub>2</sub> = Internal diameter

d<sub>8</sub> = External diameter

The construction dimensions for DN 15 and DN 450 are not defined in DIN 2848.

DN	Possible vacuum		
	23°C	100°C	230°C
25			
40			
50			
80			
100			
150			
200			
250			
300			

Vacuum resistance:

-  = full vacuum
-  = limited vacuum
-  = no vacuum

Please refer to the next diameter nominal if your diameter nominal is not listed.

## Spacers Form G (PN 10)

For lengths from 20 – 60 mm we reinforce the spacers Form G with a resilient metal core.

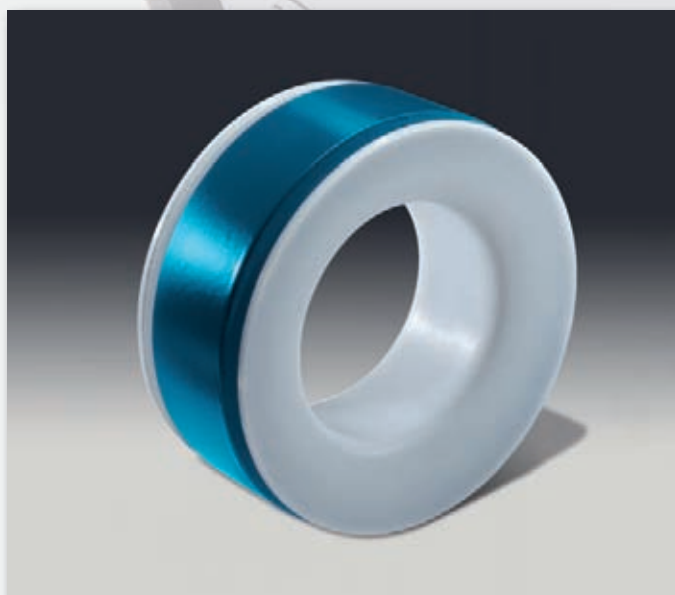

# Spacers Form G (PN 10)

Lining-materials:

- PTFE (virgin or conductive)
- PP (up to diameter nominal DN 300)

Other pressure rates:

- PN 16
- PN 25
- PN 40

Material: carbon steel and stainless steel

Special features:

- earthing studs
- final painting

Spacers Form G are also available as **inclined spacers** with various degrees.



DN	L (mm)		d <sub>1</sub> (mm)	d <sub>2</sub> (mm)	d <sub>8</sub> (mm)	Weight (ca. kg/m)
	min.	max.				
15	15	60	21,3	14	50	0,9
20	15	60	26,9	16	60	1,2
25	15	60	33,7	22	70	1,8
32	15	60	42,4	31	82	2,1
40	15	60	48,3	37	92	2,6
50	15	60	60,3	48	107	3,7
65	15	60	76,1	64	127	4,7
80	15	70	88,9	76	142	6,3
100	15	70	114,3	101	162	9,5
125	15	70	139,7	125	192	11,0
150	20	80	168,3	153	218	14,0
200	20	80	219,1	201	273	18,0
250	20	90	273,0	254	328	29,0
300	20	90	323,9	303	378	30,0
350	25	90	355,6	333	438	50,0
400	25	90	406,4	382	488	60,0
450	25	100	457,0	430	540	71,0
500	25	100	508,0	480	594	75,0

Standard lengths available from stock:  
25 mm - 30 mm - 40 mm - 50 mm

L = Total length

d<sub>1</sub> = External diameter of the pipe

d<sub>2</sub> = Internal diameter

d<sub>8</sub> = External diameter

The construction dimensions for DN 15 and DN 450 are not defined in DIN 2848.

DN	Standard	Lining thickness (mm)	Possible vacuum		
			23°C	100°C	230°C
25	●	3	Full	Full	Full
		4	Full	Full	Full
40	●	3	Full	Full	Limited
		4	Full	Full	Limited
50	●	3	Full	Full	Limited
		4	Full	Full	Limited
80	●	3	Full	Full	Limited
		4	Full	Full	Limited
100	●	3	Limited	Limited	Limited
		4,5	Limited	Limited	Limited
150	●	5	Limited	Limited	Limited
		6	Limited	Limited	Limited
200	●	5	Limited	Limited	Limited
		6	Limited	Limited	Limited
250	●	5	Limited	Limited	Limited
		7,5	Limited	Limited	Limited
300	●	5	Limited	Limited	Limited
		7,5	Limited	Limited	Limited

### Vacuum resistance:

 = full vacuum

 = limited vacuum

 = no vacuum

Please refer to the next diameter nominal if your diameter nominal is not listed.

## Spacers Form H (PN 10)

Spacers Form H with a length of more than 60 mm consist of a pressure-resistant, but lightweighted metal core with interior lining.

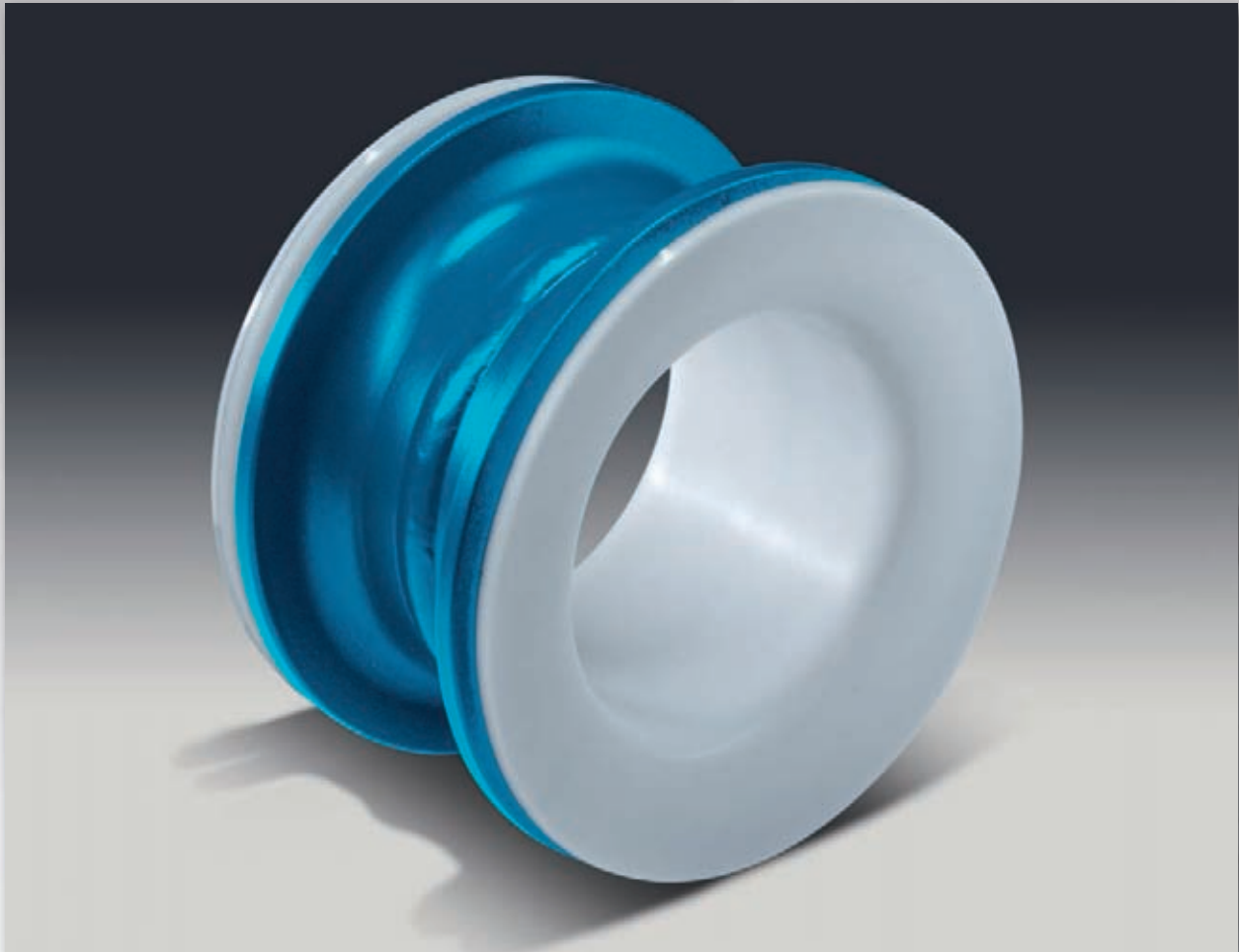

# Spacers Form H (PN 10)

Lining-materials:

- PTFE (virgin or conductive)
- PP (up to the dimension DN 300)

Other pressure rates:

- PN 16
- PN 25
- PN 40

Material: carbon steel and stainless steel

Special features: earthing studs, earthing lugs, flange stopper, field flaring pipes, final painting.

Form H

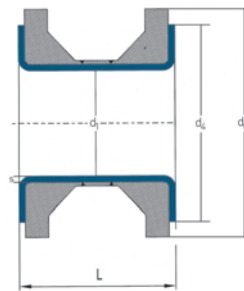

DN	L (mm)		d <sub>1</sub> (mm)	s (mm) Standard	d <sub>4</sub> (mm)	d <sub>8</sub> (mm)	Weights	
	min.	max.					Pipe (ca. kg/m)	Pair of flanges (ca. kg)
15	60	100	21,3	3	45	50	1,2	0,25
20	60	100	26,9	3	58	60	1,6	0,45
25	60	100	33,7	3	68	70	2,5	0,55
32	60	100	42,4	3	78	82	3,4	0,70
40	60	100	48,3	3	88	92	4,5	0,90
50	60	100	60,3	3	102	107	5,8	1,30
65	60	100	76,1	3	122	127	7,1	1,60
80	70	125	88,9	3	138	142	10,0	2,30
100	70	125	114,3	3	158	162	14,0	2,70
125	70	150	139,7	4,5	188	192	17,5	4,00
150	80	150	168,3	5	212	218	23,5	4,50
200	80	200	219,1	5	268	273	39,0	6,50
250	90	200	273,0	5	320	328	55,5	9,00
300	90	200	323,9	5	370	378	74,0	10,00
350	90	250	355,6	5	430	438	85,0	14,00
400	90	250	406,4	5	482	488	102,0	17,00
450	100	250	457,0	5	532	540	130,0	20,00
500	100	250	508,0	5	585	594	155,0	23,00

Standard lengths available from stock:  
60 mm - 70 mm - 80 mm

L = Total length

d<sub>1</sub> = External diameter of the pipe

s = Lining thickness

d<sub>4</sub> = Flaring diameter

d<sub>8</sub> = External diameter

The construction dimensions for DN 15 and DN 450 are not defined in DIN 2848.

DN	Standard	Lining thickness (mm)	Possible vacuum		
			23°C	100°C	230°C
25	●	3			
		4			
40	●	3			
		4			
50	●	3			
		4			
80	●	3			
		4			
100	●	3			
		4,5			
150	●	5			
		6			
200	●	5			
		6			
250	●	5			
		7,5			
300	●	5			
		7,5			

**Vacuum resistance:**

- = full vacuum
- = limited vacuum
- = no vacuum

Please refer to the next diameter nominal if your diameter nominal is not listed.

## Inclined spacer (PN 10)

Flexible in every situation! The angled spacers can be delivered in any angle, tapered on one side only or on both sides.

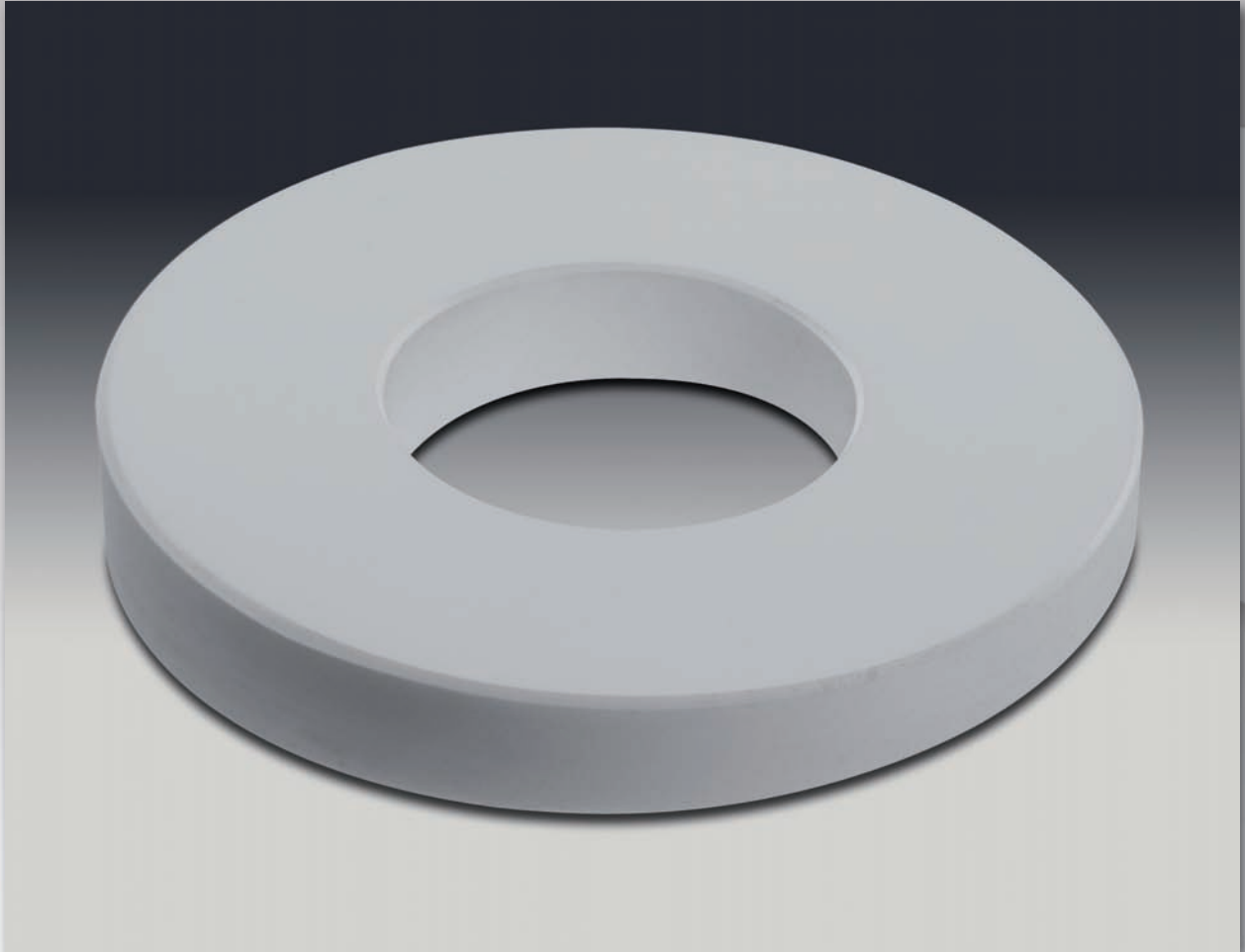

# Inclined spacer (PN 10)

Design:

- Steel / PTFE (virgin or conductive)
- solid PTFE (virgin or conductive)

Other pressure rates:

- PN 16
- PN 25
- PN 40































Standard angle for inclined spacer: 3°

Other angles upon request.



DN	L (mm)	Weight (ca. kg/m)
25	15	1,8
32	15	2,1
40	15	2,6
50	20	3,7
65	20	4,7
80	20	6,3
100	25	9,5

L = Total length



DN	Standard	Lining thickness (mm)	Possible vacuum		
			23°C	100°C	230°C
25	●	3			
		4			
40	●	3			
		4			
50	●	3			
		4			
80	●	3			
		4			
100	●	3			
		4,5			

#### Vacuum resistance:

-  = full vacuum
-  = limited vacuum
-  = no vacuum

Please refer to the next diameter nominal if your diameter nominal is not listed.



## Elbows





## Elbows 30° / 60° (PN 10)

The BAUM manufacturing technology with paste-extruded PTFE assures an optimum flow and an exact fitting of the liner in the elbow segment.

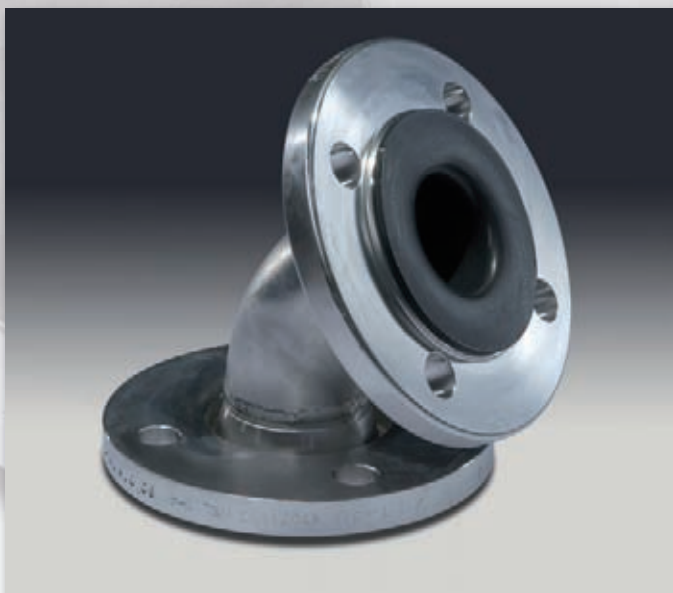
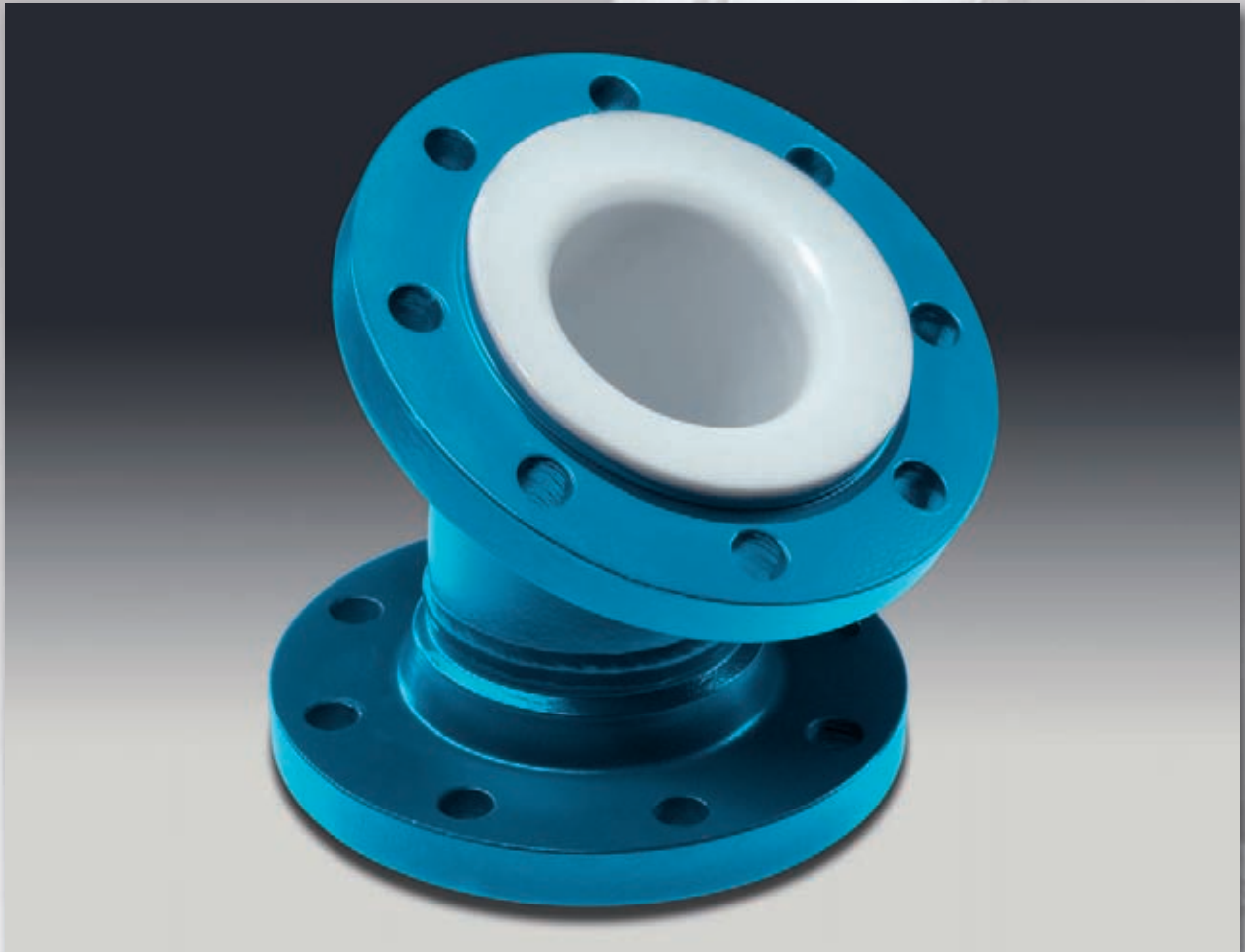

# Elbows 30° / 60° (PN 10)

Lining-materials:

- PTFE (virgin or conductive)
- PP (up to diameter nominal DN 300)

Different lining thicknesses on request.

Flange design:

- fix-loose
- fix-fix
- loose-loose

Other pressure rates:

- PN 16
- PN 25
- PN 40

Material: carbon steel and stainless steel

Special features: earthing studs, earthing lugs, final painting.

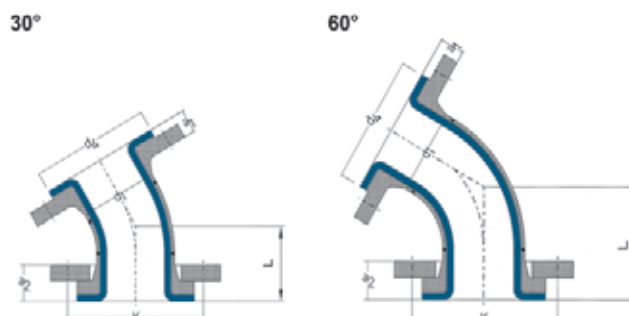

DN	L [mm]		d <sub>1</sub> (mm)	d <sub>4</sub> (mm)	K (mm)	a <sub>1</sub> (mm)	a <sub>2</sub> (mm)	Screws	Weights	
	30°	60°							30° (ca. kg/piece)	60° (ca. kg/piece)
15	50	63	21,3	45	65	19,0	29,0	4 x M 12	1,5	1,6
20	57	75	26,9	58	75	21,0	33,0	4 x M 12	2,0	2,2
25	61	84	33,7	68	85	21,0	33,0	4 x M 12	2,7	2,8
32	70	98	42,4	78	100	21,0	35,0	4 x M 16	3,9	4,1
40	73	108	48,3	88	110	21,0	35,0	4 x M 16	4,6	4,9
50	70	93	60,3	102	125	21,0	38,0	4 x M 16	5,8	6,1
65	75	104	76,1	122	145	21,0	39,0	4 x M 16	7,2	7,6
80	85	120	88,9	138	160	23,0	39,0	8 x M 16	9,1	9,7
100	96	145	114,3	158	180	23,0	43,0	8 x M 16	11,6	12,7
125	106	166	139,7	188	210	26,5	44,5	8 x M 16	15,3	17,1
150	118	188	168,3	212	240	27,0	49,0	8 x M 20	19,6	23,0
200	145	240	219,1	268	295	29,0	49,0	8 x M 20	30,0	37,0
250	168	286	273,0	320	350	31,0	53,0	12 x M 20	43,0	54,0
300	190	330	323,9	370	400	31,0	53,0	12 x M 20	57,0	74,5
350	210	375	355,6	430	460	31,0	55,0	16 x M 20	74,0	138,0
400	235	425	406,4	482	515	31,0	61,0	16 x M 24	102,0	160,0
450	205	415	457,0	532	565	33,0	65,0	20 x M 24	125,0	200,0
500	275	508	508,0	585	585	33,0	69,0	20 x M 24	162,0	230,0

L = Total length

d<sub>1</sub> = External diameter of the pipe

d<sub>4</sub> = Flaring diameter



K = Bolt circle

a<sub>1</sub> = Length with fixed flange (standard lining)

a<sub>2</sub> = Length with loose flange (standard lining)

DN	Standard	Lining thickness (mm)	Possible vacuum		
			23°C	100°C	230°C
25	●	3	Full	Full	Full
		4	Full	Full	Full
40	●	3	Full	Full	Limited
		4	Full	Full	Full
50	●	3	Full	Full	Limited
		4	Full	Full	Full
80	●	4,5	Full	Full	Full
100	●	4,5	Full	Full	Limited
150	●	6,5	Full	Full	Limited
200	●	7	Full	Full	Limited
250	●	7,5	Full	Limited	Limited
300	●	7,5	Full	Limited	Limited

#### Vacuum resistance:

-  = full vacuum
-  = limited vacuum
-  = no vacuum

Please refer to the next diameter nominal if your diameter nominal is not listed.

## Elbows 45° / 90° (PN 10)

The BAUM manufacturing technology with paste-extruded PTFE assures an optimum flow and an exact fitting of the liner in the elbow segment.

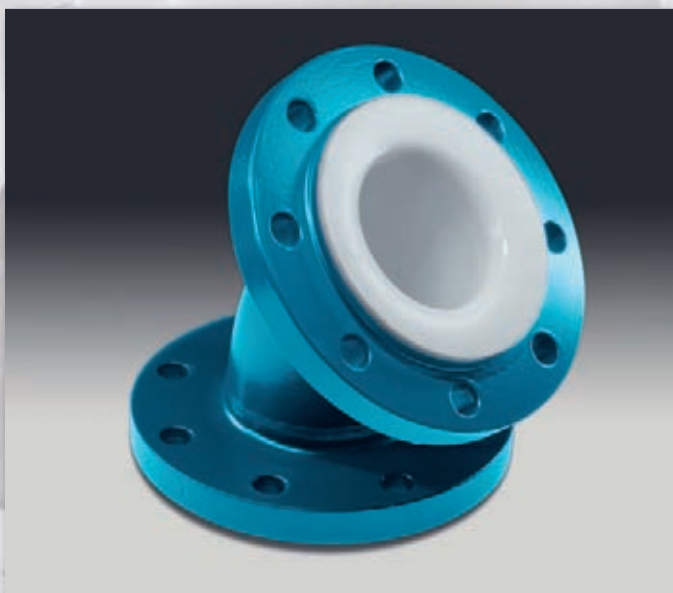

# Elbows 45° / 90° (PN 10)

Lining-materials:

- PTFE (virgin or conductive)
- PP (up to diameter nominal DN 300, except DN 65 and DN 125)

Different lining thicknesses on request.

Flange design:

- fix-loose
- fix-fix
- loose-loose

Other pressure rates:

- PN 16
- PN 25
- PN 40

Material: carbon steel and stainless steel Special features: earthing studs, earthing lugs, final painting.

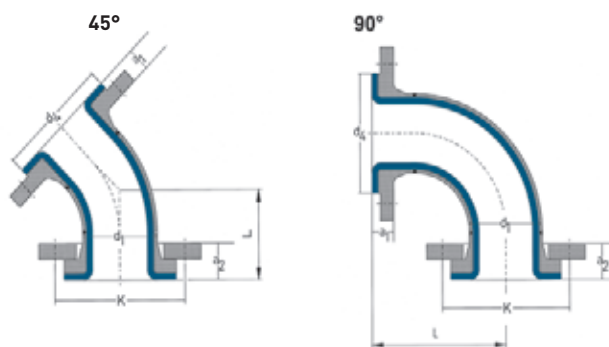

DN	L (mm)				d <sub>1</sub> (mm)	d <sub>4</sub> (mm)	K (mm)	a <sub>1</sub> (mm)	a <sub>2</sub> (mm)	Screws	Weights	
	45°	90°	45°	90°							45°	90°
	Form C	Form A	Form D	Form B							(ca. kg/pce.)	(ca. kg/pce.)
15	Use Form D	Use Form B	60	85	21,3	45	65	19,0	29,0	4 x M 12	1,5	1,5
20			65	95	26,9	58	75	21,0	33,0	4 x M 12	2,1	2,1
25			70	110	33,7	68	85	21,0	33,0	4 x M 12	2,7	2,7
32			80	130	42,4	78	100	21,0	35,0	4 x M 16	4,0	4,0
40			90	150	48,3	88	110	21,0	35,0	4 x M 16	4,6	4,6
50	80	120	105	180	60,3	102	125	21,0	38,0	4 x M 16	5,9	5,9
65	85	140	120	220	76,1	122	145	21,0	39,0	4 x M 16	7,5	7,5
80	100	165	135	255	88,9	138	160	23,0	39,0	8 x M 16	9,6	9,6
100	115	205	165	320	114,3	158	180	23,0	43,0	8 x M 16	13,1	13,1
125	135	245	190	385	139,7	188	210	26,5	44,5	8 x M 16	18,1	18,1
150	150	285	215	440	168,3	212	240	27,0	49,0	8 x M 20	26,0	30,0
200	190	365	270	570	219,1	268	295	29,0	49,0	8 x M 20	39,0	47,0
250	225	450	335	710	273,0	320	350	31,0	53,0	12 x M 20	62,0	76,0
300	260	525	385	830	323,9	370	400	31,0	53,0	12 x M 20	76,0	95,0
350	290	600	430	910	355,6	430	460	31,0	55,0	16 x M 20	110,0	142,0
400	325	680	480	1030	406,4	482	515	31,0	61,0	16 x M 24	141,0	185,0
450	280	700	445	1140	457,0	532	565	33,0	65,0	20 x M 24	194,0	255,0
500	390	830	585	1300	508,0	585	585	33,0	69,0	20 x M 24	225,0	300,0



DN	Standard	Lining thickness (mm)	Possible vacuum		
			23°C	100°C	230°C
25	●	3	Full	Full	Full
		4	Full	Full	Full
40	●	3	Full	Full	Limited
		4	Full	Full	Limited
50	●	3	Full	Full	Limited
		4	Full	Full	Limited
80	●	4,5	Full	Full	Limited
100	●	4,5	Full	Full	Limited
150	●	6,5	Full	Full	Limited
200	●	7	Full	Full	Limited
250	●	7,5	Full	Full	Limited
300	●	7,5	Full	Full	Limited

Available from stock:  
flange design fix-loose und fix-fix

- L = Total length
- d<sub>1</sub> = External diameter of the pipe
- d<sub>4</sub> = Flaring diameter
- K = Bolt circle
- a<sub>1</sub> = Length with fixed flange(standard lining)
- a<sub>2</sub> = Length with loose flange (standard lining)

The construction dimensions for DN 15 and DN 450 are not defined in DIN 2848.

#### Vacuum resistance:

-  = full vacuum
-  = limited vacuum
-  = no vacuum

Please refer to the next diameter nominal if your diameter nominal is not listed.

Due to technical issues several Elbows may be delivered in 2 parts.



## Tees





## Tees (PN 10)

The one-piece design with PFA assures a perfect flow in the base body and at the outlet. The manufacturing of our PFA-Tees is done by injection moulding (Extruder). For tees with nominal widths larger than DN 100, we rely on our approved paste liner. Both manufacturing technologies assure a specially smooth and easy-to-clean surface.

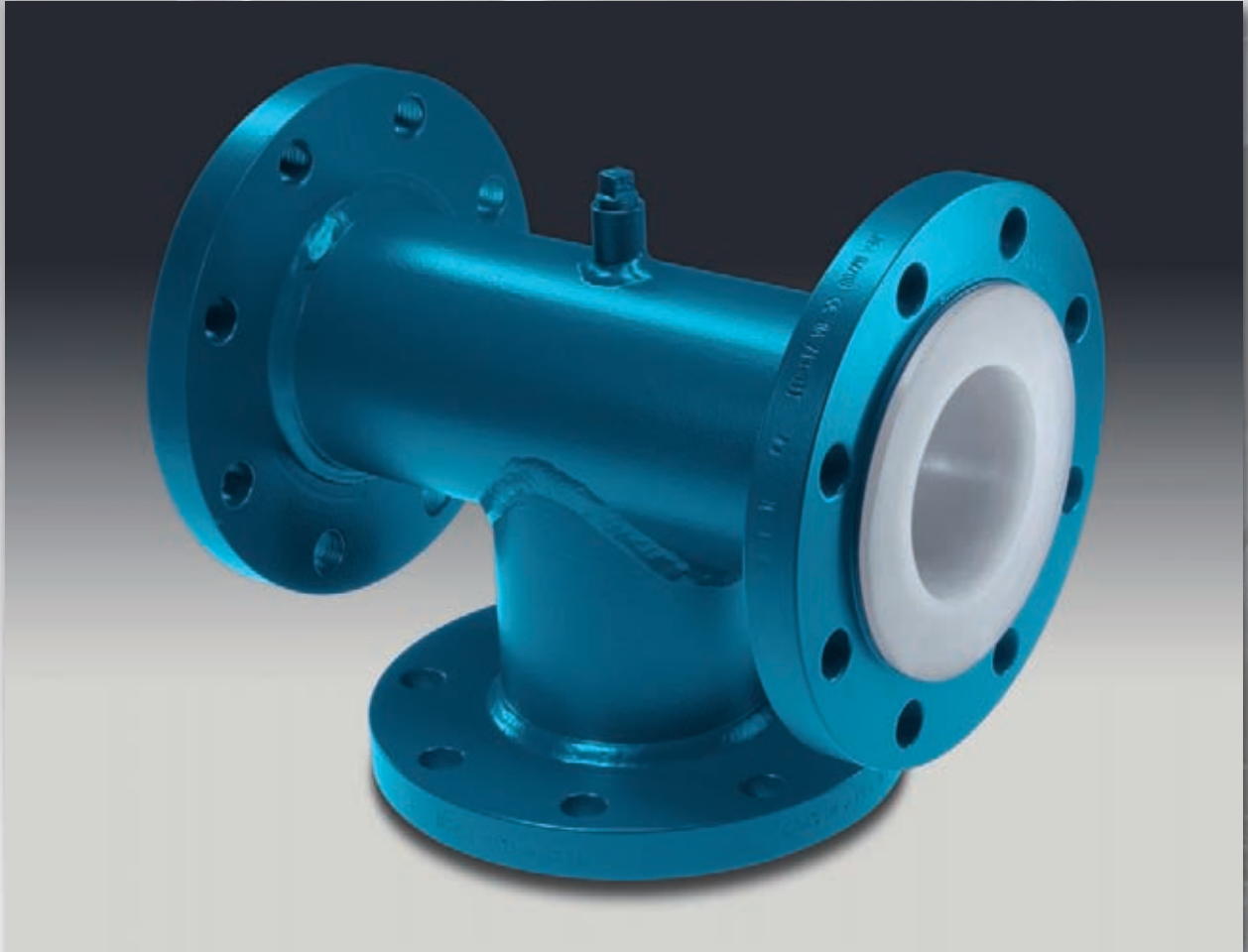

# Tees (PN 10)

Lining-materials:

- up to diameter nominal DN<sub>1</sub> 100 (one-piece): PFA (virgin or conductive)
- from diameter nominal DN<sub>1</sub> 125 (two-piece): PTFE (virgin or conductive)
- up to diameter nominal DN<sub>1</sub> 300 (two-piece): PP

PFA-lined tees are also available as **Lateral tees**.

Different lining thicknesses and flange designs on request.

Flange design:

- loose-loose-loose
- fix-loose-loose
- fix-fix-fix

Other pressure rates:

- PN 16
- PN 25
- PN 40

Material: carbon steel and stainless steel

Special features: earthing studs, earthing lugs, flange stopper, final painting.

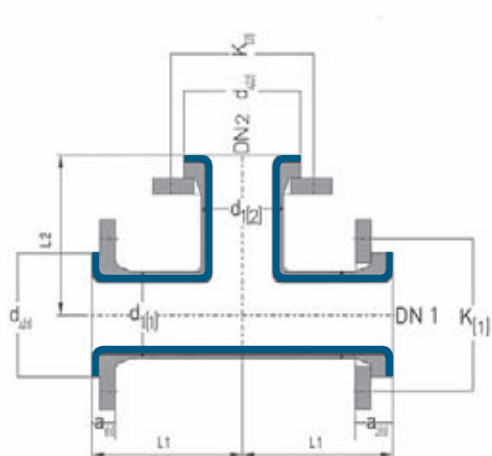

one-piece

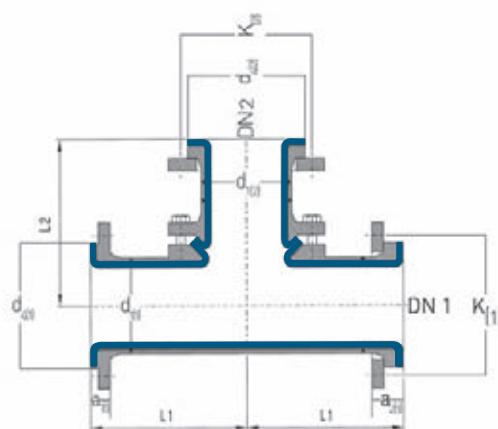

two-piece

DN <sub>1</sub>	DN <sub>2</sub>	L <sub>1</sub> (mm)	L <sub>2</sub> (mm)	d <sub>1(1)</sub> (mm)	d <sub>4(1)</sub> (mm)	K <sub>1(1)</sub> (mm)	a <sub>1(1)</sub> (mm)	a <sub>2(1)</sub> (mm)	d <sub>1(2)</sub> (mm)	d <sub>4(2)</sub> (mm)	K <sub>1(2)</sub> (mm)	a <sub>1(2)</sub> (mm)	a <sub>2(2)</sub> (mm)	Screws		Wt. (ca. kg/ piece)
														(1)	(2)	
15	15	85	85	21,3	45	65	19,0	29,0	21,3	45	65	19,0	29,0	4xM12	4xM12	2,5
20	20	95	95	26,9	58	75	21,0	33,0	26,9	58	75	21,0	33,0	4xM12	4xM12	3,2
20	15		85						21,3	45	65	19,0	29,0	4xM12	4xM12	3,1
25	25	110	110	33,7	68	85	21,0	33,0	33,7	68	85	21,0	33,0	4xM12	4xM12	5,5
25	20		95						26,9	58	75	21,0	33,0	4xM12	4xM12	3,9
25	15		85						21,3	45	65	19,0	29,0	4xM12	4xM12	3,7
32	32	130	130	42,4	78	100	21,0	35,0	42,4	78	100	21,0	35,0	4xM16	4xM16	8,0
32	25		110						33,7	68	85	21,0	33,0	4xM16	4xM12	7,0
32	20		100						26,9	58	75	21,0	33,0	4xM16	4xM12	6,0
32	15		85						21,3	45	65	19,0	29,0	4xM16	4xM12	5,6
40	40	150	150	48,3	88	110	21,0	35,0	48,3	88	110	21,0	35,0	4xM16	4xM16	9,5
40	32	150	130	48,3	88	110	21,0	35,0	42,4	78	100	21,0	35,0	4xM16	4xM16	9,0
40	25	150	110	48,3	88	110	21,0	35,0	33,7	68	85	21,0	33,0	4xM16	4xM12	8,0
40	20	150	100	48,3	88	110	21,0	35,0	26,9	58	75	21,0	33,0	4xM16	4xM12	7,0
50	50	120	120	60,3	102	125	21,0	38,0	60,3	102	125	21,0	38,0	4xM16	4xM16	11,5
50	40	120	150	60,3	102	125	21,0	38,0	48,3	88	110	21,0	35,0	4xM16	4xM16	10,5
50	32	120	130	60,3	102	125	21,0	38,0	42,4	78	100	21,0	35,0	4xM16	4xM16	9,3
50	25	120	110	60,3	102	125	21,0	38,0	33,7	68	85	21,0	33,0	4xM16	4xM12	8,9

continued

# Tees (PN 10)

DN <sub>1</sub>	DN <sub>2</sub>	L <sub>1</sub> (mm)	L <sub>2</sub> (mm)	d <sub>1(1)</sub> (mm)	d <sub>4(1)</sub> (mm)	K <sub>(1)</sub> (mm)	a <sub>1(1)</sub> (mm)	a <sub>2(1)</sub> (mm)	d <sub>1(2)</sub> (mm)	d <sub>4(2)</sub> (mm)	K <sub>(2)</sub> (mm)	a <sub>1(2)</sub> (mm)	a <sub>2(2)</sub> (mm)	Screws		Wt. (ca. kg/ piece)
														(1)	(2)	
65	65	140	140	76,1	122	145	21,0	39,0	76,1	122	145	21,0	39,0	4xM16	4xM16	14,5
65	50	140	120	76,1	122	145	21,0	39,0	60,3	102	125	21,0	38,0	4xM16	4xM16	13,0
65	40	140	150	76,1	122	145	21,0	39,0	48,3	88	110	21,0	35,0	4xM16	4xM16	12,5
65	32	140	130	76,1	122	145	21,0	39,0	42,4	78	100	21,0	35,0	4xM16	4xM16	12,0
65	25	140	110	76,1	122	145	21,0	39,0	33,7	68	85	21,0	33,0	4xM16	4xM12	11,5
80	80	165	165	88,9	138	160	23,0	39,0	88,9	138	160	23,0	39,0	8xM16	8xM16	19,5
80	65	165	140	88,9	138	160	23,0	39,0	76,1	122	145	21,0	39,0	8xM16	4xM16	18,0
80	50	165	120	88,9	138	160	23,0	39,0	60,3	102	125	21,0	38,0	8xM16	4xM16	17,5
80	40	165	150	88,9	138	160	23,0	39,0	48,3	88	110	21,0	35,0	8xM16	4xM16	17,0
80	25	165	110	88,9	138	160	23,0	39,0	33,7	68	85	21,0	33,0	8xM16	4xM12	16,0
100	100	205	205	114,3	158	180	23,0	43,0	114,3	158	180	23,0	43,0	8xM16	8xM16	24,0
100	80	205	165	114,3	158	180	23,0	43,0	88,9	138	160	23,0	39,0	8xM16	8xM16	24,0
100	65	205	140	114,3	158	180	23,0	43,0	76,1	122	145	21,0	39,0	8xM16	4xM16	23,0
100	50	205	120	114,3	158	180	23,0	43,0	60,3	102	125	21,0	38,0	8xM16	4xM16	22,0
100	25	205	110	114,3	158	180	23,0	43,0	33,7	68	85	21,0	33,0	8xM16	4xM12	19,0
125	125	245	245	139,7	188	210	26,5	44,5	139,7	188	210	26,5	44,5	8xM16	8xM16	34,0
125	100		205						114,3	158	180	23,0	43,0	8xM16	8xM16	28,0
125	80		165						88,9	138	160	23,0	39,0	8xM16	8xM16	27,0
125	65		140						76,1	122	145	21,0	39,0	8xM16	4xM16	26,0
150	150	285	285	168,3	212	240	27,0	49,0	168,3	212	240	27,0	49,0	8xM20	8xM20	45,0
150	125	285	245	168,3	212	240	27,0	49,0	139,7	188	210	26,5	44,5	8xM20	8xM16	37,0
150	100	285	205	168,3	212	240	27,0	49,0	114,3	158	180	23,0	43,0	8xM20	8xM16	35,4
150	80	285	165	168,3	212	240	27,0	49,0	88,9	138	160	23,0	39,0	8xM20	8xM16	34,0
200	200	365	365	219,1	268	295	29,0	49,0	219,1	268	295	29,0	49,0	8xM20	8xM20	72,0
200	150		285						168,3	212	240	27,0	49,0	8xM20	8xM20	68,0
200	125		245						139,7	188	210	26,5	44,5	8xM20	8xM16	65,0
200	100		205						114,3	158	180	23,0	43,0	8xM20	8xM16	63,0
250	250	450	450	273,0	320	350	31,0	53,0	273,0	320	350	31,0	53,0	12xM20	12xM20	150,0
250	200		365						219,1	268	295	29,0	49,0	12xM20	8xM20	100,0
250	150		285						168,3	212	240	27,0	49,0	12xM20	8xM20	94,0
250	125		245						139,7	188	210	26,5	44,5	12xM20	8xM16	88,0
300	300	525	525	323,9	370	400	31,0	53,0	323,9	370	400	31,0	53,0	12xM20	12xM20	210,0
300	250		450						273,0	320	350	31,0	53,0	12xM20	12xM20	175,0
300	200		365						219,1	268	295	29,0	49,0	12xM20	8xM20	140,0
300	150		285						168,3	212	240	27,0	49,0	12xM20	8xM20	134,0
350	350	600	600	355,6	430	460	31,0	55,0	355,6	430	460	31,0	55,0	16xM20	16xM20	312,0
350	300		525						323,9	370	400	31,0	53,0	16xM20	12xM20	295,0
350	250		450						273,0	320	350	31,0	53,0	16xM20	12xM20	285,0
350	200		365						219,1	268	295	29,0	49,0	16xM20	8xM20	278,0

continued





























# Tees (PN 10)

DN <sub>1</sub>	DN <sub>2</sub>	L <sub>1</sub> (mm)	L <sub>2</sub> (mm)	d <sub>1(1)</sub> (mm)	d <sub>4(1)</sub> (mm)	K <sub>(1)</sub> (mm)	a <sub>1(1)</sub> (mm)	a <sub>2(1)</sub> (mm)	d <sub>1(2)</sub> (mm)	d <sub>4(2)</sub> (mm)	K <sub>(2)</sub> (mm)	a <sub>1(2)</sub> (mm)	a <sub>2(2)</sub> (mm)	Screws		Wt.  (ca. kg/ piece)
														(1)	(2)	
400	400	680	680	406,4	482	515	31,0	61,0	406,6	482	515	31,0	61,0	16xM24	16xM24	375,0
400	350		600						355,6	430	460	31,0	55,0	16xM24	16xM20	360,0
400	300		525						323,9	370	400	31,0	53,0	16xM24	12xM20	348,0
400	250		450						273,0	320	350	31,0	53,0	16xM24	12xM20	320,0
450	450	680	680	457,0	532	565	33,0	65,0	457,0	532	565	33,0	65,0	20xM24	20xM24	460,0
450	400		680						406,4	482	515	31,0	61,0	20xM24	16xM24	454,0
450	350		600						355,6	430	460	31,0	55,0	20xM24	16xM20	445,0
450	300		525						323,9	370	400	31,0	53,0	20xM24	12xM20	437,0
500	500	830	830	508,0	585	585	33,0	69,0	508,0	585	585	33,0	69,0	20xM24	20xM24	420,0
500	450		680						457,0	532	565	33,0	65,0	20xM24	20xM24	406,0
500	400		680						406,4	482	515	31,0	61,0	20xM24	16xM24	395,0
500	350		600						355,6	430	460	31,0	55,0	20xM24	16xM20	384,0
500	300		525						323,9	370	400	31,0	53,0	20xM24	12xM20	365,0



Available from stock:  
flange design fix-loose

- L = Total length
- d<sub>1</sub> = External diameter of the pipe
- d<sub>4</sub> = Flaring diameter
- K = Bolt circle
- a<sub>1</sub> = Length with fixed flange (standard lining)
- a<sub>2</sub> = Length with loose flange (standard lining)

The construction dimensions for DN 15 and DN 450 are not defined in DIN 2848.

DN	Standard	Lining thickness (mm)	possible vacuum		
			23°C	100°C	230°C
25	●	3			
40	●	3			
50	●	3			
80	●	4			
100	●	4			
150	●	6			
200	●	6			
250	●	7			
300	●	7			

#### Vacuum resistance:

-  = full vacuum
-  = limited vacuum
-  = no vacuum

Please refer to the next diameter nominal if your diameter nominal is not listed.

## Lateral tees 45° (PN 10)

The one-piece design with PFA offers a low-resistance flow through the entire component by a streamlined geometry.



# Lateral tees 45° (PN 10)

- Lining-materials:
- PTFE (virgin or conductive)
  - PP

Different lining thicknesses and flange designs on request.

- Flange design:
- loose-loose-loose
  - fix-loose-loose
  - fix-fix-fix

- Other pressure rates:
- PN 16
  - PN 25
  - PN 40

Material: carbon steel and stainless steel

Special features: earthing studs, earthing lugs, flange stopper, final painting.

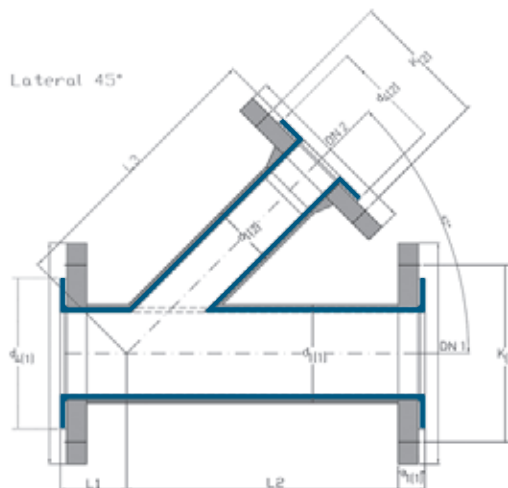

DN <sub>1</sub>	DN <sub>2</sub>	L <sub>1</sub> (mm)	L <sub>2</sub> (mm)	L <sub>3</sub> (mm)	d <sub>1(1)</sub> (mm)	d <sub>4(1)</sub> (mm)	K <sub>(1)</sub> (mm)	a <sub>1(1)</sub> (mm)	a <sub>2(1)</sub> (mm)	d <sub>1(2)</sub> (mm)	d <sub>4(2)</sub> (mm)	K <sub>(2)</sub> (mm)	a <sub>1(2)</sub> (mm)	a <sub>2(2)</sub> (mm)	Screws		Wt. (ca. kg/ piece)
															(1)	(2)	
25	25	60	160	160	33,7	68	85	21,0	21,0	33,7	68	85	21,0	33,0	4xM12	4xM12	5,2
40	40	90	210	200	48,3	88	110	21,0	35,0	48,3	88	110	21,0	35,0	4xM16	4xM16	8,1
40	25			180						33,7	68	85	21,0	33,0	4xM16	4xM12	7,5
50	50	50	190	230	60,3	102	125	21,0	38,0	60,3	102	125	21,0	38,0	4xM16	4xM16	11,4
50	40			220						48,3	88	110	21,0	35,0	4xM16	4xM16	10,5
50	25			190						33,7	68	85	21,0	33,0	4xM16	4xM12	10,0
80	80	60	270	270	88,9	138	160	23,0	39,0	88,9	138	160	23,0	39,0	8xM16	8xM16	24,0
80	50			250						60,3	102	125	21,0	38,0	8xM16	4xM14	21,0
80	25			230						33,7	68	85	21,0	33,0	8xM16	4xM12	19,5
100	100	115	295	295	114,3	158	180	23,0	43,0	114,3	158	180	23,0	43,0	8xM16	8xM16	44,0
100	80			295						88,9	138	160	23,0	39,0	8xM16	8xM16	40,0
100	50			270						60,3	102	125	21,0	38,0	8xM16	4xM16	38,0
100	25			250						33,7	68	85	21,0	33,0	8xM16	4xM12	35,0

- L = Total length
- d<sub>1</sub> = External diameter of the pipe
- d<sub>4</sub> = Flaring diameter
- K = Bolt circle
- a<sub>1</sub> = Length with fixed flange (standard lining)
- a<sub>2</sub> = Length with loose flange (standard lining)

DN	Standard	Lining thickness (mm)	Possible vacuum		
			23°C	100°C	230°C
25	●	3			
40	●	3			
50	●	3			
80	●	4			
100	●	4			
150	●	6			
200	●	6			
250	●	7			
300	●	7			



## Crosses



## Crosses (PN 10)

The one-piece design with PFA assures a perfect flow in all four directions. Crosses larger than DN 100 are manufactured with paste liner.



# Crosses (PN 10)

## Lining-Materials:

- up to diameter nominal DN<sub>1</sub> 100 (one-piece): PFA (virgin or conductive)
- from diameter nominal DN<sub>1</sub> 125 (two-piece): PTFE (virgin or conductive)
- up to diameter nominal DN<sub>1</sub> 300 (two-piece): PP From Standard

Different lining thicknesses and flange designs on request.

## Flange design:

- fix-loose-fix-loose
- fix-fix-fix-fix
- loose-loose-loose-loose

## Other pressure rates:

- PN 16
- PN 25
- PN 40

Material: carbon steel and stainless steel

Special features: earthing studs, earthing lugs, flange stopper, final painting.

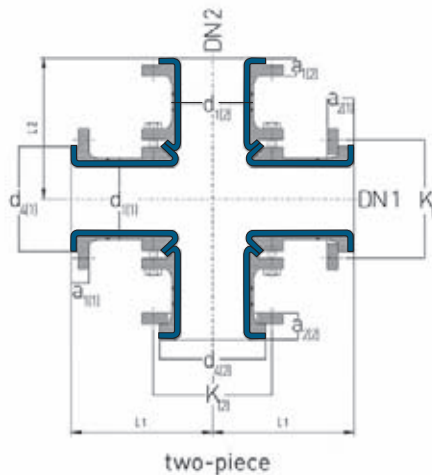
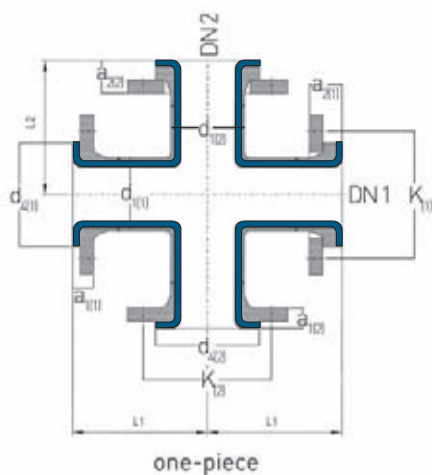

DN <sub>1</sub>	DN <sub>2</sub>	L <sub>1</sub> (mm)	L <sub>2</sub> (mm)	d <sub>1(1)</sub> (mm)	d <sub>4(1)</sub> (mm)	K <sub>1(1)</sub> (mm)	a <sub>1(1)</sub> (mm)	a <sub>2(1)</sub> (mm)	d <sub>1(2)</sub> (mm)	d <sub>4(2)</sub> (mm)	K <sub>1(2)</sub> (mm)	a <sub>1(2)</sub> (mm)	a <sub>2(2)</sub> (mm)	Screws		Wt. (ca. kg/ piece)
														(1)	(2)	
15	15	85	85	21,3	45	65	19,0	29,0	21,3	45	65	19,0	29,0	4xM12	4xM12	3,1
20	20	95	95	26,9	58	75	21,0	33,0	26,9	58	75	21,0	33,0	4xM12	4xM12	5,0
20	15		85						21,3	45	65	19,0	29,0	4xM12	4xM12	4,5
25	25	110	110	33,7	68	85	21,0	33,0	33,7	68	85	21,0	33,0	4xM12	4xM12	8,5
25	20	110	95	33,7	68	85	21,0	33,0	26,9	58	75	21,0	33,0	4xM12	4xM12	7,8
25	15	110	85	33,7	68	85	21,0	33,0	21,3	45	65	19,0	29,0	4xM12	4xM12	7,5
32	32	130	130	42,4	78	100	21,0	35,0	42,4	78	100	21,0	35,0	4xM16	4xM16	11,0
32	25		110						33,7	68	85	21,0	33,0	4xM16	4xM12	10,0
32	20		100						26,9	58	75	21,0	33,0	4xM16	4xM12	9,5
32	15		85						21,3	45	65	19,0	29,0	4xM16	4xM12	8,0
40	40	150	150	48,3	88	110	21,0	35,0	48,3	88	110	21,0	35,0	4xM16	4xM16	14,0
40	32	150	130	48,3	88	110	21,0	35,0	42,4	78	100	21,0	35,0	4xM16	4xM16	13,4
40	25	150	110	48,3	88	110	21,0	35,0	33,7	68	85	21,0	33,0	4xM16	4xM12	11,5
40	20	150	100	48,3	88	110	21,0	35,0	26,9	58	75	21,0	33,0	4xM16	4xM12	10,6
50	50	120	120	60,3	102	125	21,0	38,0	60,3	102	125	21,0	38,0	4xM16	4xM16	17,0
50	40	120	150	60,3	102	125	21,0	38,0	48,3	88	110	21,0	35,0	4xM16	4xM16	16,0
50	32	120	130	60,3	102	125	21,0	38,0	42,4	78	100	21,0	35,0	4xM16	4xM16	15,0
50	25	120	110	60,3	102	125	21,0	38,0	33,7	68	85	21,0	33,0	4xM16	4xM12	13,0

continued

# Crosses (PN 10)

DN <sub>1</sub>	DN <sub>2</sub>	L <sub>1</sub> (mm)	L <sub>2</sub> (mm)	d <sub>1(1)</sub> (mm)	d <sub>4(1)</sub> (mm)	K <sub>(1)</sub> (mm)	a <sub>1(1)</sub> (mm)	a <sub>2(1)</sub> (mm)	d <sub>1(2)</sub> (mm)	d <sub>4(2)</sub> (mm)	K <sub>(2)</sub> (mm)	a <sub>1(2)</sub> (mm)	a <sub>2(2)</sub> (mm)	Screws		Wt. (ca. kg/ piece)
														(1)	(2)	
65	65	140	140	76,1	122	145	21,0	39,0	76,1	122	145	21,0	39,0	4xM16	4xM16	22,0
65	50		120						60,3	102	125	21,0	38,0	4xM16	4xM16	21,0
65	40		150						48,3	88	110	21,0	35,0	4xM16	4xM16	18,0
65	32		130						42,4	78	100	21,0	35,0	4xM16	4xM16	17,0
65	25		110						33,7	68	85	21,0	33,0	4xM16	4xM12	15,0
80	80	165	165	88,9	138	160	23,0	39,0	88,9	138	160	23,0	39,0	8xM16	8xM16	26,5
80	65	165	140	88,9	138	160	23,0	39,0	76,1	122	145	21,0	39,0	8xM16	4xM16	25,0
80	50	165	120	88,9	138	160	23,0	39,0	60,3	102	125	21,0	38,0	8xM16	4xM16	22,5
80	40	165	150	88,9	138	160	23,0	39,0	48,3	88	110	21,0	35,0	8xM16	4xM16	20,5
80	25	165	110	88,9	138	160	23,0	39,0	33,7	68	85	21,0	33,0	8xM16	4xM12	17,5
100	100	205	205	114,3	158	180	23,0	43,0	114,3	158	180	23,0	43,0	8xM16	8xM16	36,0
100	80	205	165	114,3	158	180	23,0	43,0	88,9	138	160	23,0	39,0	8xM16	8xM16	34,0
100	65	205	140	114,3	158	180	23,0	43,0	76,1	122	145	21,0	39,0	8xM16	4xM16	29,5
100	50	205	120	114,3	158	180	23,0	43,0	60,3	102	125	21,0	38,0	8xM16	4xM16	28,0
100	25	205	110	114,3	158	180	23,0	43,0	33,7	68	85	21,0	33,0	8xM16	4xM12	23,5
125	125	245	245	139,7	188	210	26,5	44,5	139,7	188	210	26,5	44,5	8xM16	8xM16	73,0
125	100		205						114,3	158	180	23,0	43,0	8xM16	8xM16	69,0
125	80		165						88,9	138	160	23,0	39,0	8xM16	8xM16	66,0
125	65		140						76,1	122	145	21,0	39,0	8xM16	4xM16	64,0
150	150	285	285	168,3	212	240	27,0	49,0	168,3	212	240	27,0	49,0	8xM20	8xM20	97,0
150	125		245						139,7	188	210	26,5	44,5	8xM20	8xM16	92,0
150	100		205						114,3	158	180	23,0	43,0	8xM20	8xM16	88,0
150	80		165						88,9	138	160	23,0	39,0	8xM20	8xM16	84,0
200	200	365	365	219,1	268	295	29,0	49,0	219,1	268	295	29,0	49,0	8xM20	8xM20	126,0
200	150		285						168,3	212	240	27,0	49,0	8xM20	8xM20	121,0
200	125		245						139,7	188	210	26,5	44,5	8xM20	8xM16	118,0
200	100		205						114,3	158	180	23,0	43,0	8xM20	8xM16	114,0
250	250	450	450	273,0	320	350	31,0	53,0	273,0	320	350	31,0	53,0	12xM20	12xM20	198,0
250	200		365						219,1	268	295	29,0	49,0	12xM20	8xM20	188,0
250	150		285						168,3	212	240	27,0	49,0	12xM20	8xM20	183,0
250	125		245						139,7	188	210	26,5	44,5	12xM20	8xM16	179,0
300	300	525	525	323,9	370	400	31,0	53,0	323,9	370	400	31,0	53,0	12xM20	12xM20	286,0
300	250		450						273,0	320	350	31,0	53,0	12xM20	12xM20	280,0
300	200		365						219,1	268	295	29,0	49,0	12xM20	8xM20	273,0
300	150		285						168,3	212	240	27,0	49,0	12xM20	8xM20	265,0
350	350	600	600	355,6	430	460	31,0	55,0	355,6	430	460	31,0	55,0	16xM20	16xM20	385,0
350	300		525						323,9	370	400	31,0	53,0	16xM20	12xM20	375,0
350	250		450						273,0	320	350	31,0	53,0	16xM20	12xM20	367,0
350	200		365						219,1	268	295	29,0	49,0	16xM20	8xM20	360,0

continued



























## Crosses (PN 10)

DN <sub>1</sub>	DN <sub>2</sub>	L <sub>1</sub> (mm)	L <sub>2</sub> (mm)	d <sub>1(1)</sub> (mm)	d <sub>4(1)</sub> (mm)	K <sub>(1)</sub> (mm)	a <sub>1(1)</sub> (mm)	a <sub>2(1)</sub> (mm)	d <sub>1(2)</sub> (mm)	d <sub>4(2)</sub> (mm)	K <sub>(2)</sub> (mm)	a <sub>1(2)</sub> (mm)	a <sub>2(2)</sub> (mm)	Screws		Wt. (ca. kg/ piece)
														(1)	(2)	
400	400	680	680	406,4	482	515	31,0	61,0	406,6	482	515	31,0	61,0	16xM24	16xM24	485,0
400	350		600						355,6	430	460	31,0	55,0	16xM24	16xM20	470,0
400	300		525						323,9	370	400	31,0	53,0	16xM24	12xM20	461,0
400	250		450						273,0	320	350	31,0	53,0	16xM24	12xM20	453,0
450	450	680	680	457,0	532	565	33,0	65,0	457,0	532	565	33,0	65,0	20xM24	20xM24	530,0
450	400		680						406,4	482	515	31,0	61,0	20xM24	16xM24	520,0
450	350		600						355,6	430	460	31,0	55,0	20xM24	16xM20	510,0
450	300		525						323,9	370	400	31,0	53,0	20xM24	12xM20	505,0
500	500	830	830	508,0	585	585	33,0	69,0	508,0	585	585	33,0	69,0	20xM24	20xM24	560,0
500	450		680						457,0	532	565	33,0	65,0	20xM24	20xM24	545,0
500	400		680						406,4	482	515	31,0	61,0	20xM24	16xM24	535,0
500	350		600						355,6	430	460	31,0	55,0	20xM24	16xM20	526,0
500	300		525						323,9	370	400	31,0	53,0	20xM24	12xM20	515,0



Available from stock:  
flange design fix-loose-fix-loose and fix-fix-fix-fix

- L = Total length
- d<sub>1</sub> = External diameter of the pipe
- d<sub>4</sub> = Flaring diameter
- K = Bolt circle
- a<sub>1</sub> = Length with fixed flange (standard lining)
- a<sub>2</sub> = Length with loose flange (standard lining)

The construction dimensions for DN 15 and DN 450 are not defined in DIN 2848.

DN	Standard	Lining thickness (mm)	Possible vacuum		
			23°C	100°C	230°C
25	●	3			
40	●	3			
50	●	3			
80	●	4			
100	●	4			
150	●	6			
200	●	6			
250	●	7			
300	●	7			

### Vacuum resistance:

-  = full vacuum
-  = limited vacuum
-  = no vacuum

Please refer to the next diameter nominal if your diameter nominal is not listed.



## Instrument-Tees

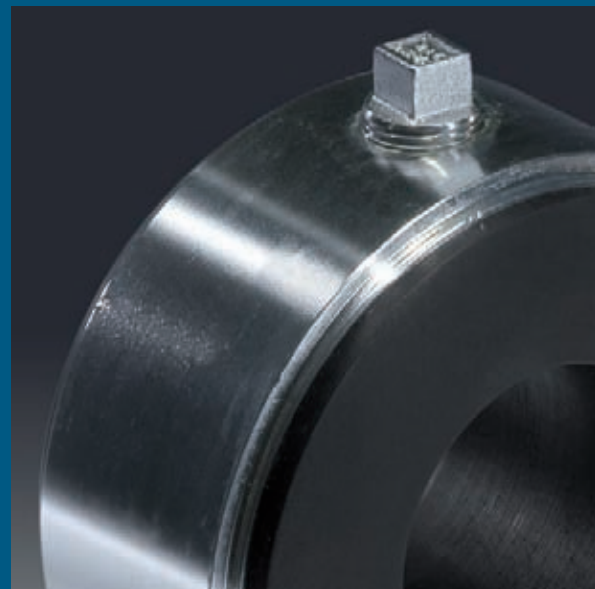

## Instrument-Tees (PN 10)

Instrument-Tees, also known as gauge connections, are the one-piece solution with PFA lining for the connection to your measuring devices. In case of narrow space, also useable as short tee.

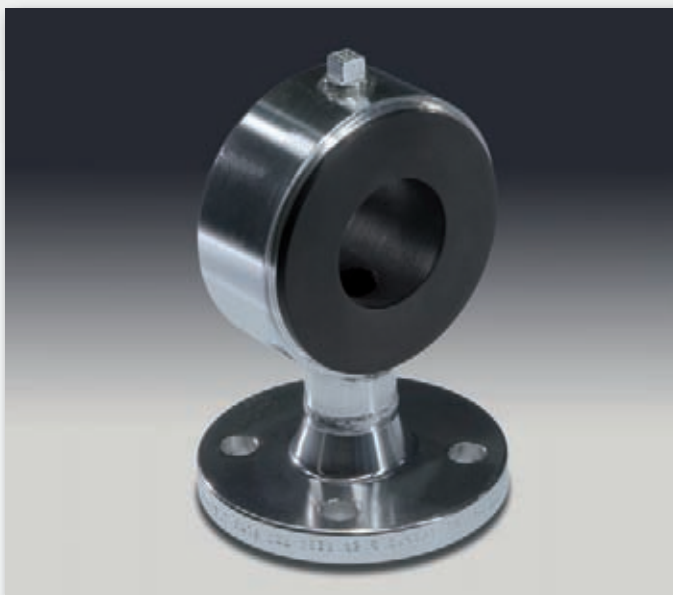
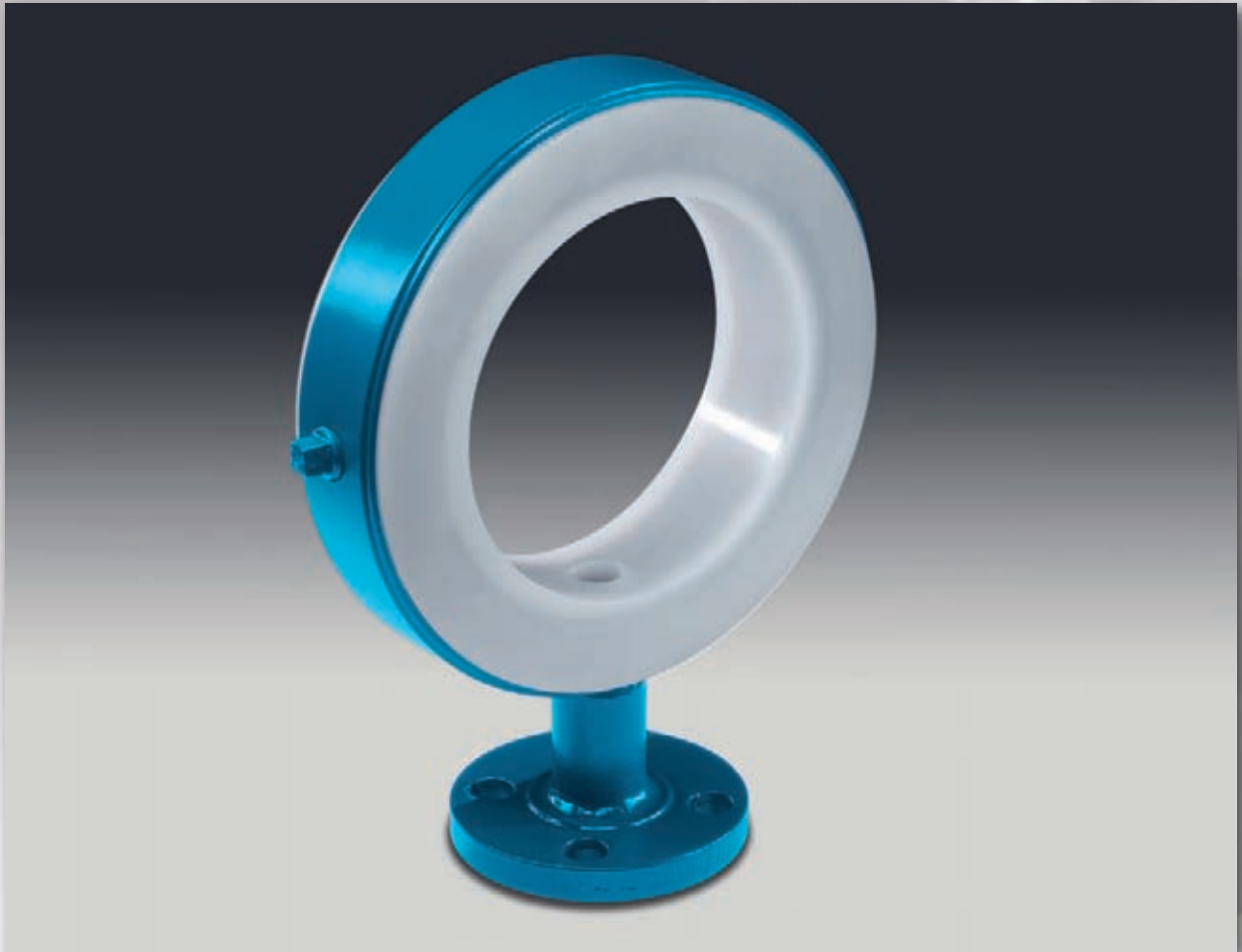

# Instrument-Tees (PN 10)

Lining-materials:

- all diameter nominal: PFA (virgin or conductive)
- up to diameter nominal DN<sub>1</sub> 300: PP
- from diameter nominal DN<sub>1</sub> 300: ETFE (unit sizes on request)

Other pressure rates:

- PN 16
- PN 25
- PN 40

Material: carbon steel and stainless steel

Special features: earthing studs, earthing lugs, final painting.

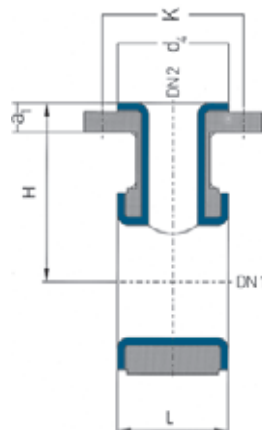

DN <sub>1</sub>	DN <sub>2</sub>	L (mm)	H (mm)	d <sub>4</sub> (mm)	K (mm)	a <sub>1</sub> (mm)	Screws	Weight (ca. kg/piece)
25	15	50	90	45	65	19,0	4 x M 12	1,9
25	20	50	90	58	75	21,0	4 x M 12	2,0
25	25	50	90	68	85	21,0	4 x M 12	2,2
32	15	50	100	45	65	19,0	4 x M 12	2,1
32	20	50	100	58	75	21,0	4 x M 12	2,3
32	25	50	100	68	85	21,0	4 x M 12	2,5
40	15	50	110	45	65	19,0	4 x M 12	2,4
40	20	50	110	58	75	21,0	4 x M 12	2,6
40	25	50	110	68	85	21,0	4 x M 12	2,8
40	40	75	110	88	110	21,0	4 x M 16	4,4
50	15	50	115	45	65	19,0	4 x M 12	3,2
50	20	50	115	58	75	21,0	4 x M 12	3,4
50	25	50	115	68	85	21,0	4 x M 12	3,6
50	40	75	115	88	110	21,0	4 x M 16	6,2
50	50	90	115	102	125	21,0	4 x M 16	8,1
65	15	50	125	45	65	19,0	4 x M 12	3,7
65	20	50	125	58	75	21,0	4 x M 12	3,8
65	25	50	125	68	85	21,0	4 x M 12	3,9
65	40	75	125	88	110	21,0	4 x M 16	7,2
65	50	90	125	102	125	21,0	4 x M 16	9,8
80	15	50	135	45	65	19,0	4 x M 12	4,3
80	20	50	135	58	75	21,0	4 x M 12	4,5
80	25	50	135	68	85	21,0	4 x M 12	4,7
80	40	75	135	88	110	21,0	4 x M 16	8,3
80	50	90	135	102	125	21,0	4 x M 16	12,6
100	15	50	150	45	65	19,0	4 x M 12	5,5
100	20	50	150	58	75	21,0	4 x M 12	5,7
100	25	50	150	68	85	21,0	4 x M 12	5,9
100	40	75	150	88	110	21,0	4 x M 16	8,9
100	50	90	150	102	125	21,0	4 x M 16	16,00

continued

# Instrument-Tees (PN 10)

DN <sub>1</sub>	DN <sub>2</sub>	L (mm)	H (mm)	d <sub>4</sub> (mm)	K (mm)	a <sub>1</sub> (mm)	Screws	Weight (ca. kg/piece)	
125	15	50	160	45	65	19,0	4 x M 12	6,6	
125	20			58	75	21,0	4 x M 12	6,8	
125	25			68	85	21,0	4 x M 12	7,0	
125	40			75	88	110	21,0	4 x M 16	12,4
125	50			90	102	125	21,0	4 x M 16	20,5
150	15	50	180	45	65	19,0	4 x M 12	7,7	
150	20	50	180	58	75	21,0	4 x M 12	7,9	
150	25	50	180	68	85	21,0	4 x M 12	8,2	
150	40	75	180	88	110	21,0	4 x M 16	14,7	
150	50	90	180	102	125	21,0	4 x M 16	21,8	
200	15	50	210	45	65	19,0	4 x M 12	9,9	
200	20	50	210	58	75	21,0	4 x M 12	10,3	
200	25	50	210	68	85	21,0	4 x M 12	10,5	
200	40	75	210	88	110	21,0	4 x M 16	17,8	
200	50	90	210	102	125	21,0	4 x M 16	23,4	
250	25	50	240	68	85	21,0	4 x M 12	13,7	
250	40	75		88	110	21,0	4 x M 16	23,2	
250	50	90		102	125	21,0	4 x M 16	25,9	
300	25	90	340	68	85	21,0	4 x M 12	43,0	
300	40	110		88	110	21,0	4 x M 16	55,5	
300	50	120		102	125	21,0	4 x M 16	62,1	
350	25	90	375	68	85	21,0	4 x M 12	53,1	
350	40	110		88	110	21,0	4 x M 16	66,5	
350	50	120		102	125	21,0	4 x M 16	73,7	
400	25	90	390	68	85	21,0	4 x M 12	59,1	
400	40	110		88	110	21,0	4 x M 16	74,5	
400	50	120		102	125	21,0	4 x M 16	83,7	
450	25	90	425	68	85	21,0	4 x M 12	68,5	
450	40	110		88	110	21,0	4 x M 16	90,5	
450	50	120		102	125	21,0	4 x M 16	93,7	
500	25	90	450	68	85	21,0	4 x M 12	72,1	
500	40	110		88	110	21,0	4 x M 16	90,5	
500	50	120		102	125	21,0	4 x M 16	100,7	

Available from stock:

L = Total length



























H = Overall height

d<sub>4</sub> = Flaring diameter

K = Bolt circle

a<sub>1</sub> = Length with fixed flange (standard lining)

The construction dimensions for DN 15 and DN 450 are not defined in DIN 2848.

DN	Standard	Lining thickness (mm)	Possible vacuum		
			23°C	100°C	230°C
25	●	3			
40	●	3			
50	●	3			
80	●	4			
100	●	4			
150	●	6			
200	●	6			
250	●	7			
300	●	7			

#### Vacuum resistance:

 = full vacuum

 = limited vacuum

 = no vacuum

Please refer to the next diameter nominal if your diameter nominal is not listed.

## Reducers



## Reducing-Flanges (PN 10)

We have a custom-made solution for transitions between all nominal widths. Depending on the reduction, lined with PTFE or PFA.

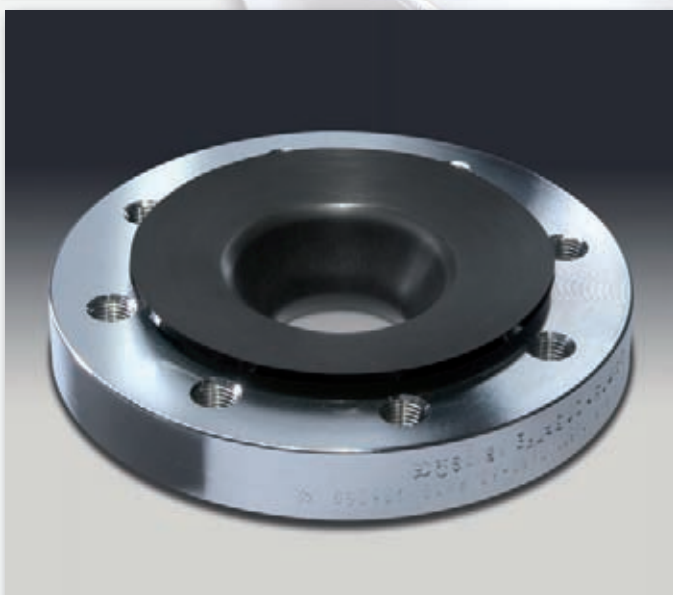
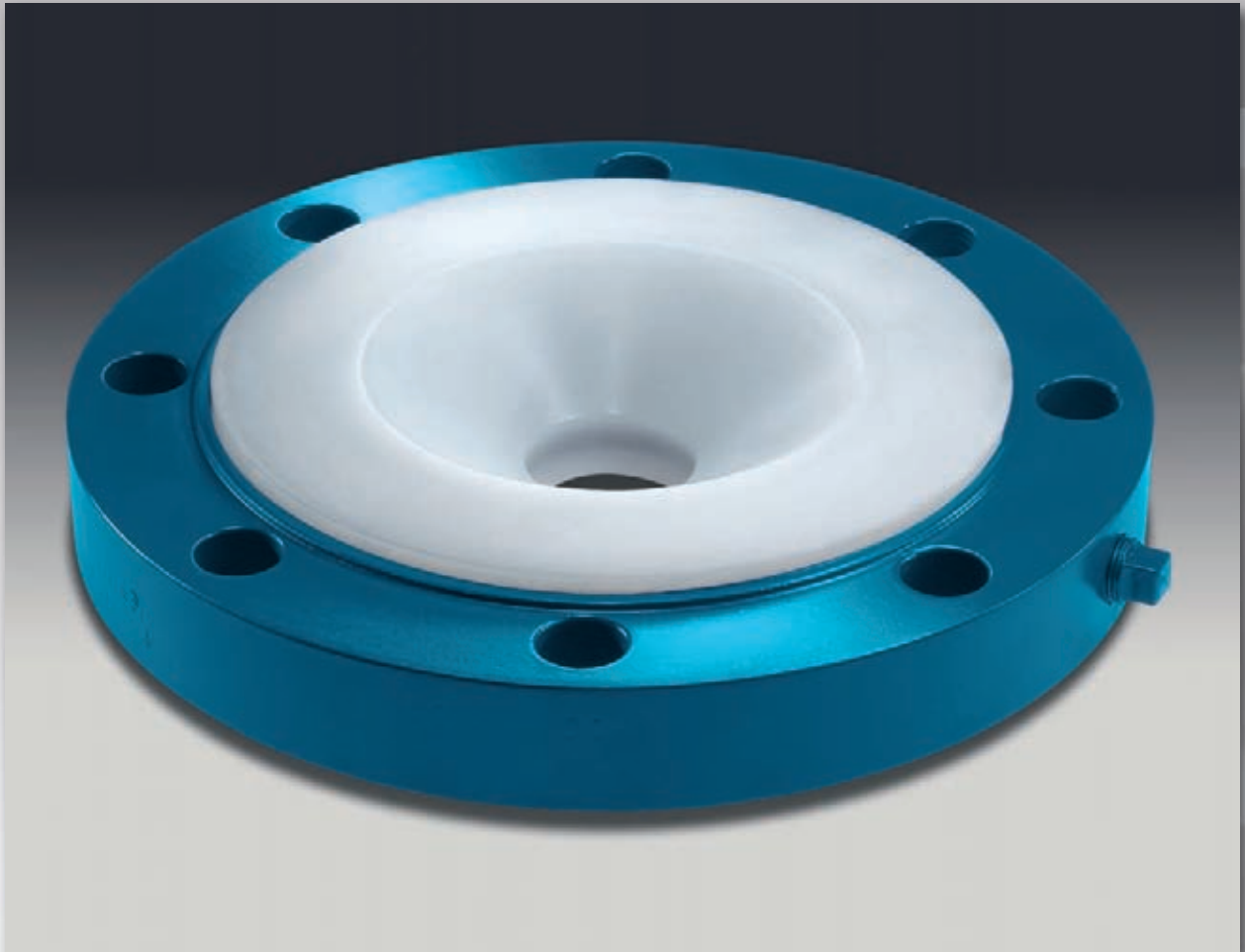

# Reducing-Flanges (PN 10)

- Lining-materials (see table):
- PTFE (virgin or conductive)
  - PFA (virgin or conductive)
  - PP

Different lining thicknesses and flange designs on request.

Other pressure rates:

- PN 16
- PN 25
- PN 40

Material: carbon steel and stainless steel

Special features: earthing studs, earthing lugs, final painting.

Excentric reducing-flanges - Form E2 and E3 - on request.

## Form K1

concentric,  
 DN<sub>1</sub>: through hole; hole position acc. DIN EN 1333  
 DN<sub>2</sub>: threaded hole; hole position acc. DIN EN 1333

## Form K2

concentric,  
 DN<sub>1</sub>: threaded bore; hole position acc. DIN EN 1333  
 DN<sub>2</sub>: threaded hole; hole position acc. DIN EN 1333

## Form K3

concentric,  
 DN<sub>1</sub>: threaded bore; hole position acc. DIN EN 1333  
 DN<sub>2</sub>: threaded bore; drillings on centerline

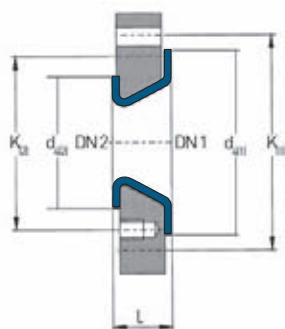

Form K1

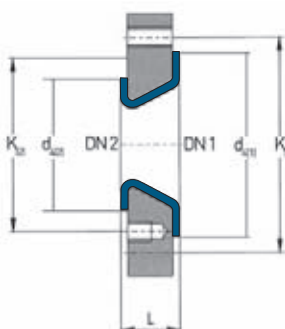

Form K2

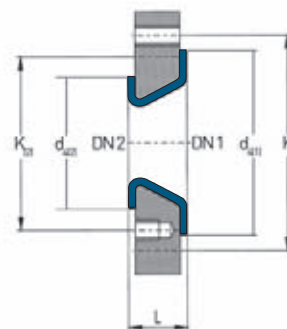

Form K3

DN <sub>1</sub>	DN <sub>2</sub>	L (mm)	Form	d <sub>4(1)</sub> (mm)	K <sub>(1)</sub> (mm)	d <sub>4(2)</sub> (mm)	K <sub>(2)</sub> (mm)	Lining-Materials	Screws	Weight (ca. kg/pc.)
20	15	35	K3	58	75	45	65	PTFE / PP	4 x M 12	2,5
25	15	35	K3	68	85	45	65	PTFE / PP	4 x M 12	2,5
25	20	35	K3	68	85	58	75	PTFE / PP	4 x M 12	2,4
32	20	35	K3	78	100	58	75	PTFE / PP	4 x M 16	3,9
32	25	35	K3	78	100	68	85	PTFE / PP	4 x M 16	3,5
40	20	35	K2	88	110	58	75	PTFE / PP	4 x M 16	4,1
40	25	35	K3	88	110	68	85	PTFE / PP	4 x M 16	4,0
40	32	35	K3	88	110	78	100	PTFE / PP	4 x M 16	3,9
50	20	35	K2	102	125	58	75	PFA / PP	4 x M 16	5,0
50	25	35	K2	102	125	68	85	PTFE / PP	4 x M 16	4,9
50	32	35	K3	102	125	78	100	PTFE / PP	4 x M 16	5,0
50	40	35	K3	102	125	88	110	PTFE / PP	4 x M 16	5,1
65	20	35	K2	122	145	58	75	PFA / PP	4 x M 16	6,0
65	25	35	K2	122	145	68	85	PFA / PP	4 x M 16	5,9
65	32	35	K2	122	145	78	100	PFA / PP	4 x M 16	5,8
65	40	35	K3	122	145	88	110	PTFE / PP	4 x M 16	5,6
65	50	35	K3	122	145	102	125	PTFE / PP	4 x M 16	5,6
80	25	35	K1	138	160	68	85	PFA / PP	8 x M 16	6,8
80	32	35	K2	138	160	78	100	PFA / PP	8 x M 16	6,7
80	40	35	K2	138	160	88	110	PFA / PP	8 x M 16	6,6
80	50	35	K2	138	160	102	125	PTFE / PP	8 x M 16	6,4
80	65	35	K2	138	160	122	145	PTFE / PP	8 x M 16	6,2

continued

## Reducing-Flanges (PN 10)

DN <sub>1</sub>	DN <sub>2</sub>	L (mm)	Form	d <sub>4(1)</sub> (mm)	K <sub>(1)</sub> (mm)	d <sub>4(2)</sub> (mm)	K <sub>(2)</sub> (mm)	Lining- Materials	Screws	Weight (ca. kg/ pc.)
100	25	45	K1	158	180	68	85	PFA / PP	8 x M 16	12,0
100	32	45	K1	158	180	78	100	PFA / PP	8 x M 16	12,0
100	40	45	K1	158	180	88	110	PFA / PP	8 x M 16	12,0
100	50	45	K2	158	180	102	125	PTFE / PP	8 x M 16	12,0
100	65	45	K2	158	180	122	145	PTFE / PP	8 x M 16	11,0
100	80	45	K3	158	180	138	160	PTFE / PP	8 x M 16	10,0
125	25	45	K1	188	210	68	85	PFA / PP	8 x M 16	16,0
125	32	45	K1	188	210	78	100	PFA / PP	8 x M 16	16,0
125	40	45	K1	188	210	88	110	PFA / PP	8 x M 16	15,0
125	50	45	K1	188	210	102	125	PFA / PP	8 x M 16	14,0
125	65	45	K2	188	210	122	145	PFA / PP	8 x M 16	13,5
125	80	45	K2	188	210	138	160	PTFE / PP	8 x M 16	13,0
125	100	45	K3	188	210	158	180	PTFE / PP	8 x M 16	13,0
150	25	45	K1	212	240	68	85	PFA / PP	8 x M 20	22,0
150	32	45	K1	212	240	78	100	PFA / PP	8 x M 20	21,0
150	40	45	K1	212	240	88	110	PFA / PP	8 x M 20	20,0
150	50	45	K1	212	240	102	125	PFA / PP	8 x M 20	19,0
150	65	45	K1	212	240	122	145	PFA / PP	8 x M 20	18,5
150	80	45	K1	212	240	138	160	PFA / PP	8 x M 20	18,0
150	100	45	K2	212	240	158	180	PTFE / PP	8 x M 20	17,0
150	125	45	K3	212	240	188	210	PTFE / PP	8 x M 20	16,0
200	50	45	K1	268	295	102	125	PFA / PP	8 x M 20	28,0
200	65	45	K1	268	295	122	145	PFA / PP	8 x M 20	27,5
200	80	45	K1	268	295	138	160	PFA / PP	8 x M 20	27,0
200	100	45	K1	268	295	158	180	PFA / PP	8 x M 20	25,0
200	125	45	K1	268	295	188	210	PTFE / PP	8 x M 20	24,0
200	150	45	K2	268	295	212	240	PTFE / PP	8 x M 20	23,0
250	65	45	K1	320	350	122	145	PFA / PP	12 x M 20	25,0
250	80	45	K1	320	350	138	160	PFA / PP	12 x M 20	24,0
250	100	45	K1	320	350	158	180	PFA / PP	12 x M 20	22,0
250	125	45	K1	320	350	188	210	PTFE / PP	12 x M 20	20,5
250	150	45	K1	320	350	212	240	PTFE / PP	12 x M 20	19,0
250	200	45	K2	320	350	268	295	PTFE / PP	12 x M 20	16,0
300	80	50	K1	370	400	138	160	PTFE / PP	12 x M 20	38,0
300	100	50	K1	370	400	158	180	PTFE / PP	12 x M 20	36,0
300	125	50	K1	370	400	188	210	PTFE / PP	12 x M 20	33,5
300	150	50	K1	370	400	212	240	PTFE / PP	12 x M 20	31,0
300	200	50	K1	370	400	268	295	PTFE / PP	12 x M 20	28,0
300	250	50	K2	370	400	320	350	PTFE / PP	12 x M 20	24,0
350	100	50	K1	430	460	158	180	PTFE	16 x M 20	47,0
350	125	50	K1	430	460	188	210	PTFE	16 x M 20	44,5
350	150	50	K1	430	460	212	240	PTFE	16 x M 20	42,0
350	200	50	K1	430	460	268	295	PTFE	16 x M 20	38,0
350	250	50	K1	430	460	320	350	PTFE	16 x M 20	35,0
350	300	50	K2	430	460	370	400	PTFE	16 x M 20	33,0

continued



## Reducing-Flanges (PN 10)

DN <sub>1</sub>	DN <sub>2</sub>	L (mm)	Form	d <sub>4(1)</sub> (mm)	K <sub>(1)</sub> (mm)	d <sub>4(2)</sub> (mm)	K <sub>(2)</sub> (mm)	Lining- Materials	Screws	Weight (ca. kg/ pc.)
400	125	50	K1	482	515	188	210	PTFE	16 x M 24	63,0
400	150	50	K1	482	515	212	240	PTFE	16 x M 24	62,0
400	200	50	K1	482	515	268	295	PTFE	16 x M 24	60,0
400	250	50	K1	482	515	320	350	PTFE	16 x M 24	55,0
400	300	50	K1	482	515	370	400	PTFE	16 x M 24	49,0
400	350	50	K2	482	515	430	460	PTFE	16 x M 24	40,0
450	150	50	K1	532	565	212	240	PTFE	20 x M 24	72,0
450	200	50	K1	532	565	268	295	PTFE	20 x M 24	70,0
450	250	50	K1	532	565	320	350	PTFE	20 x M 24	66,0
450	300	50	K1	532	565	370	400	PTFE	20 x M 24	58,0
450	350	50	K1	532	565	430	460	PTFE	20 x M 24	49,0
450	400	50	K2	532	565	482	515	PTFE	20 x M 24	44,0
500	150	50	K1	585	585	212	240	PTFE	20 x M 24	87,0
500	200	50	K1	585	585	268	295	PTFE	20 x M 24	86,0
500	250	50	K1	585	585	320	350	PTFE	20 x M 24	85,0
500	300	50	K1	585	585	370	400	PTFE	20 x M 24	77,0
500	350	50	K1	585	585	430	460	PTFE	20 x M 24	70,0
500	400	50	K1	585	585	482	515	PTFE	20 x M 24	62,0



























Available from stock.

L = Total length



d<sub>4</sub> = Flaring diameter

K = Bolt circle

The construction dimensions for DN 15 and DN 450 are not defined in DIN 2848.

DN	Standard	Lining thickness (mm)	Possible vacuum		
			23°C	100°C	230°C
25	●	3			
40	●	3			
50	●	3			
80	●	4			
100	●	4			
150	●	6			
200	●	6			
250	●	7			
300	●	7			

#### Vacuum resistance:

-  = full vacuum
-  = limited vacuum
-  = no vacuum

Please refer to the next diameter nominal if your diameter nominal is not listed.

## Reducers concentric (PN 10)

Concentric reducers are the universal solution for all changes of the nominal pipe size. Depending on the nominal width, the reducers are lined with PTFE or with PFA.

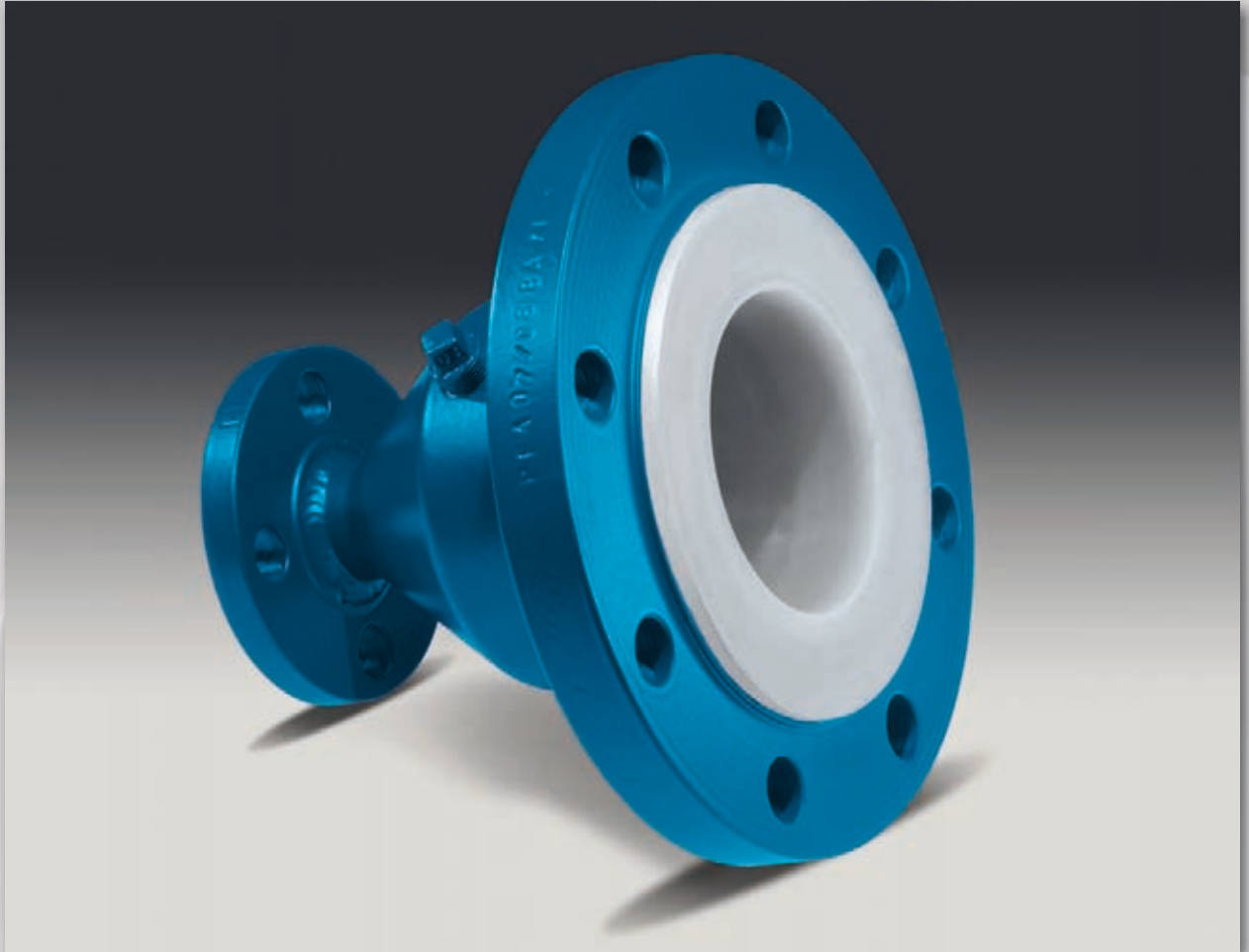

# Reducers concentric (PN 10)

- Lining-materials (see table):
- PTFE (virgin or conductive)
  - PFA (virgin or conductive)
  - PP

Different lining thicknesses and flange designs on request.

Flange design:

- fix-fix
- fix-loose
- loose-loose

Other pressure rates:

- PN 16
- PN 25
- PN 40

Material: carbon steel and stainless steel

Special features: earthing studs, earthing lugs, final painting.

All **diameter combinations printed in bold** are manufactured in two parts.

All other combinations of nominal widths on request.

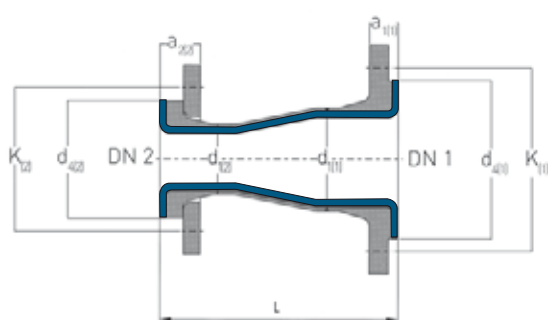

one-piece

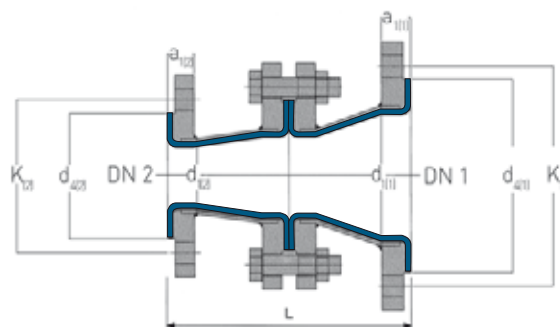

two-piece

DN <sub>1</sub>	DN <sub>2</sub>	L (mm)	d <sub>1(1)</sub> (mm)	d <sub>4(1)</sub> (mm)	K <sub>(1)</sub> (mm)	a <sub>1(1)</sub> (mm)	a <sub>2(1)</sub> (mm)	d <sub>1(2)</sub> (mm)	d <sub>4(2)</sub> (mm)	K <sub>(2)</sub> (mm)	a <sub>1(2)</sub> (mm)	a <sub>2(2)</sub> (mm)	Lining-Materials	Screws		Wt. (ca. kg/pc.)
														(1)	(2)	
20	15	125	26,9	58	75	21,0	33,0	21,3	45	65	19,0	29,0	PTFE/PP	4xM12	4xM12	2,1
25	20	125	33,7	68	85	21,0	33,0	26,9	58	75	21,0	33,0	PTFE/PP	4xM12	4xM12	2,3
25	15	125	33,7	68	85	21,0	33,0	21,3	45	65	19,0	29,0	PTFE/PP	4xM12	4xM12	2,4
32	25	130	42,2	78	100	21,0	35,0	33,7	68	85	21,0	33,0	PTFE/PP	4xM16	4xM12	3,0
32	20	130	42,2	78	100	21,0	35,0	26,9	58	75	21,0	33,0	PTFE/PP	4xM16	4xM12	2,8
40	32	150	48,3	88	110	21,0	35,0	42,2	78	100	21,0	35,0	PTFE/PP	4xM16	4xM16	3,8
40	25	145	48,3	88	110	21,0	35,0	33,7	68	85	21,0	33,0	PFA / PP	4xM16	4xM12	3,3
40	20	145	48,3	88	110	21,0	35,0	26,9	58	75	21,0	33,0	PFA/PP	4xM16	4xM12	3,1
50	40	165	60,3	102	125	21,0	38,0	48,3	88	110	21,0	35,0	PTFE/PP	4xM16	4xM16	4,8
50	32	165	60,3	102	125	21,0	38,0	42,2	78	100	21,0	35,0	PTFE/PP	4xM16	4xM16	4,3
50	25	160	60,3	102	125	21,0	38,0	33,7	68	85	21,0	33,0	PFA / PP	4xM16	4xM12	4,1
65	50	185	76,1	122	145	21,0	39,0	60,3	102	125	21,0	38,0	PTFE/PP	4xM16	4xM16	7,0
65	40	180	76,1	122	145	21,0	39,0	48,3	88	110	21,0	35,0	PTFE/PP	4xM16	4xM16	6,4
65	32	180	76,1	122	145	21,0	39,0	42,2	78	100	21,0	35,0	PFA / PP	4xM16	4xM16	6,1
80	65	190	88,9	138	160	23,0	39,0	76,1	122	145	21,0	39,0	PTFE/PP	8xM16	4xM16	7,5
80	50	190	88,9	138	160	23,0	39,0	60,3	102	125	21,0	38,0	PTFE/PP	8xM16	4xM16	6,9
80	40	185	88,9	138	160	23,0	39,0	48,3	88	110	21,0	35,0	PFA / PP	8xM16	4xM16	6,3
80	25	185	88,9	138	160	23,0	39,0	33,7	68	85	21,0	33,0	PFA / PP	8xM16	4xM12	6,7
100	80	205	114,3	158	180	23,0	43,0	88,9	138	160	23,0	39,0	PTFE/PP	8xM16	8xM16	12,3
100	65	200	114,3	158	180	23,0	43,0	76,1	122	145	21,0	39,0	PTFE/PP	8xM16	4xM16	10,6
100	50	200	114,3	158	180	23,0	43,0	60,3	102	125	21,0	38,0	PFA / PP	8xM16	4xM16	9,9
125	100	235	139,7	188	210	26,5	44,5	114,3	158	180	23,0	43,0	PTFE/PP	8xM16	8xM16	15,0
125	80	235	139,7	188	210	26,5	44,5	88,9	138	160	23,0	39,0	PFA / PP	8xM16	8xM16	12,8
125	65	230	139,7	188	210	26,5	44,5	76,1	122	145	21,0	39,0	PFA / PP	8xM16	4xM16	11,0

continued



























# Reducers concentric (PN 10)

DN <sub>1</sub>	DN <sub>2</sub>	L (mm)	d <sub>1(1)</sub> (mm)	d <sub>4(1)</sub> (mm)	K <sub>(1)</sub> (mm)	a <sub>1(1)</sub> (mm)	a <sub>2(1)</sub> (mm)	d <sub>1(2)</sub> (mm)	d <sub>4(2)</sub> (mm)	K <sub>(2)</sub> (mm)	a <sub>1(2)</sub> (mm)	a <sub>2(2)</sub> (mm)	Lining-Materials	Screws		Wt. (ca. kg/pc.)
														(1)	(2)	
150	125	250	168,3	212	240	27,0	49,0	139,7	188	210	26,5	44,5	PTFE/PP	8xM20	8xM16	20,1
150	100	250	168,3	212	240	27,0	49,0	114,3	158	180	23,0	43,0	PTFE/PP	8xM20	8xM16	18,3
150	80	250	168,3	212	240	27,0	49,0	88,9	138	160	23,0	39,0	PFA/PP	8xM20	8xM16	17,4
200	150	270	219,1	268	295	29,0	49,0	168,3	212	240	27,0	49,0	PTFE/PP	8xM20	8xM20	25,2
200	125		219,1	268	295	29,0	49,0	139,7	188	210	26,5	44,5	PTFE/PP	8xM20	8xM16	23,8
<b>200</b>	<b>100</b>		<b>219,1</b>	<b>268</b>	<b>295</b>	<b>29,0</b>	<b>49,0</b>	<b>114,3</b>	<b>158</b>	<b>180</b>	<b>23,0</b>	<b>43,0</b>	<b>PTFE/PP</b>	<b>8xM20</b>	<b>8xM16</b>	<b>22,1</b>
250	200	310	273,0	320	350	31,0	53,0	219,1	268	295	29,0	49,0	PTFE/PP	12xM20	8xM20	44,8
250	150	305	273,0	320	350	31,0	53,0	168,3	212	240	27,0	49,0	PTFE/PP	12xM20	8xM20	37,8
<b>250</b>	<b>125</b>		<b>273,0</b>	<b>320</b>	<b>350</b>	<b>31,0</b>	<b>53,0</b>	<b>139,7</b>	<b>188</b>	<b>210</b>	<b>26,5</b>	<b>44,5</b>	<b>PTFE/PP</b>	<b>12xM20</b>	<b>8xM16</b>	<b>35,0</b>
300	250	340	323,9	370	400	31,0	53,0	273,0	320	350	31,0	53,0	PTFE/PP	12xM20	12xM20	52,6
300	200	335	323,9	370	400	31,0	53,0	219,1	268	295	29,0	49,0	PTFE/PP	12xM20	8xM20	48,0
<b>300</b>	<b>150</b>	<b>330</b>	<b>323,9</b>	<b>370</b>	<b>400</b>	<b>31,0</b>	<b>53,0</b>	<b>168,3</b>	<b>212</b>	<b>240</b>	<b>27,0</b>	<b>49,0</b>	<b>PTFE/PP</b>	<b>12xM20</b>	<b>8xM20</b>	<b>46,0</b>
350	300	465	355,6	430	460	31,0	55,0	323,9	370	400	31,0	53,0	PTFE	16xM20	12xM20	80,0
<b>350</b>	<b>250</b>		<b>355,6</b>	<b>430</b>	<b>460</b>	<b>31,0</b>	<b>55,0</b>	<b>273,0</b>	<b>320</b>	<b>350</b>	<b>31,0</b>	<b>53,0</b>	<b>PTFE</b>	<b>16xM20</b>	<b>12xM20</b>	<b>73,6</b>
<b>350</b>	<b>200</b>		<b>355,6</b>	<b>430</b>	<b>460</b>	<b>31,0</b>	<b>55,0</b>	<b>219,1</b>	<b>268</b>	<b>295</b>	<b>29,0</b>	<b>49,0</b>	<b>PTFE</b>	<b>16xM20</b>	<b>8xM20</b>	<b>69,0</b>
400	350	495	406,4	482	515	31,0	61,0	355,6	430	460	31,0	55,0	PTFE	16xM24	16xM20	115,0
<b>400</b>	<b>300</b>		<b>406,4</b>	<b>482</b>	<b>515</b>	<b>31,0</b>	<b>61,0</b>	<b>323,9</b>	<b>370</b>	<b>400</b>	<b>31,0</b>	<b>53,0</b>	<b>PTFE</b>	<b>16xM24</b>	<b>12xM20</b>	<b>105,0</b>
<b>400</b>	<b>250</b>		<b>406,4</b>	<b>482</b>	<b>515</b>	<b>31,0</b>	<b>61,0</b>	<b>273,0</b>	<b>320</b>	<b>350</b>	<b>31,0</b>	<b>53,0</b>	<b>PTFE</b>	<b>16xM24</b>	<b>12xM20</b>	<b>98,0</b>
450	350	495	457,0	532	565	33,0	65,0	355,6	430	460	31,0	55,0	PTFE	20xM24	16xM20	148,0
<b>450</b>	<b>300</b>		<b>457,0</b>	<b>532</b>	<b>565</b>	<b>33,0</b>	<b>65,0</b>	<b>323,9</b>	<b>370</b>	<b>400</b>	<b>31,0</b>	<b>53,0</b>	<b>PTFE</b>	<b>20xM24</b>	<b>12xM20</b>	<b>135,0</b>
<b>450</b>	<b>250</b>		<b>457,0</b>	<b>532</b>	<b>565</b>	<b>33,0</b>	<b>65,0</b>	<b>273,0</b>	<b>320</b>	<b>350</b>	<b>31,0</b>	<b>53,0</b>	<b>PTFE</b>	<b>20xM24</b>	<b>12xM20</b>	<b>122,0</b>
500	400	650	508,0	585	585	33,0	69,0	406,4	482	515	31,0	61,0	PTFE	20xM24	16xM24	210,0
<b>500</b>	<b>350</b>		<b>508,0</b>	<b>585</b>	<b>585</b>	<b>33,0</b>	<b>69,0</b>	<b>355,6</b>	<b>430</b>	<b>460</b>	<b>31,0</b>	<b>55,0</b>	<b>PTFE</b>	<b>20xM24</b>	<b>16xM20</b>	<b>198,0</b>
<b>500</b>	<b>300</b>		<b>508,0</b>	<b>585</b>	<b>585</b>	<b>33,0</b>	<b>69,0</b>	<b>323,9</b>	<b>370</b>	<b>400</b>	<b>31,0</b>	<b>53,0</b>	<b>PTFE</b>	<b>20xM24</b>	<b>12xM20</b>	<b>185,0</b>



Available from stock:  
flange design fix-loose and fix-fix

- L = Total length
- d<sub>1</sub> = External diameter of the pipe
- d<sub>4</sub> = Flaring diameter
- K = Bolt circle
- a<sub>1</sub> = Length with fixed flange (standard lining)
- a<sub>2</sub> = Length with loose flange (standard lining)

The construction dimensions for DN 15 and DN 450 are not defined in DIN 2848.

DN	Standard	Lining thickness (mm)	Possible vacuum		
			23°C	100°C	230°C
25	●	3			
40	●	3			
50	●	3			
80	●	4			
100	●	4			
150	●	6			
200	●	6			
250	●	7			
300	●	7			

**Vacuum resistance:**

-  = full vacuum
-  = limited vacuum
-  = no vacuum

Please refer to the next diameter nominal if your diameter nominal is not listed.

## Reducers excentric (PN 10)

In case of horizontal installation, excentric reducers enable the complete idling of pipe sections. Depending on the nominal width, the reducers are lined with PTFE or with PFA.

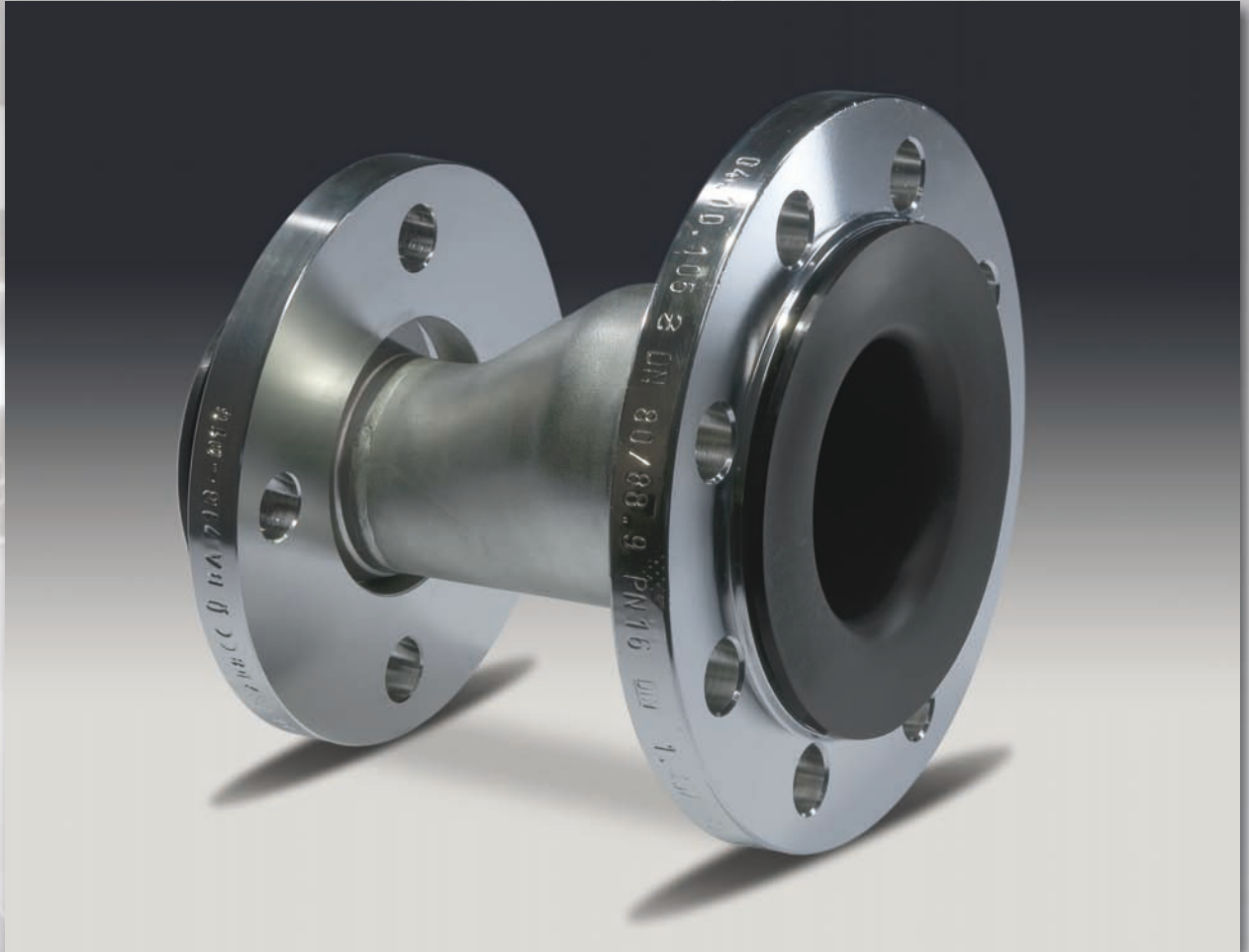

# Reducers excentric (PN 10)

- Lining-materials (see table):
- PTFE (virgin or conductive)
  - PFA (virgin or conductive)
  - PP

Different lining thicknesses and flange designs on request.

- Flange design:
- fix-fix
  - fix-loose
  - loose-loose

Other pressure rates:

- PN 16
- PN 25
- PN 40

Material: carbon steel and stainless steel

Special features: earthing studs, earthing lugs, final painting.

All **diameter combinations printed in bold** are manufactured in two parts.

All other combinations of nominal widths on request.

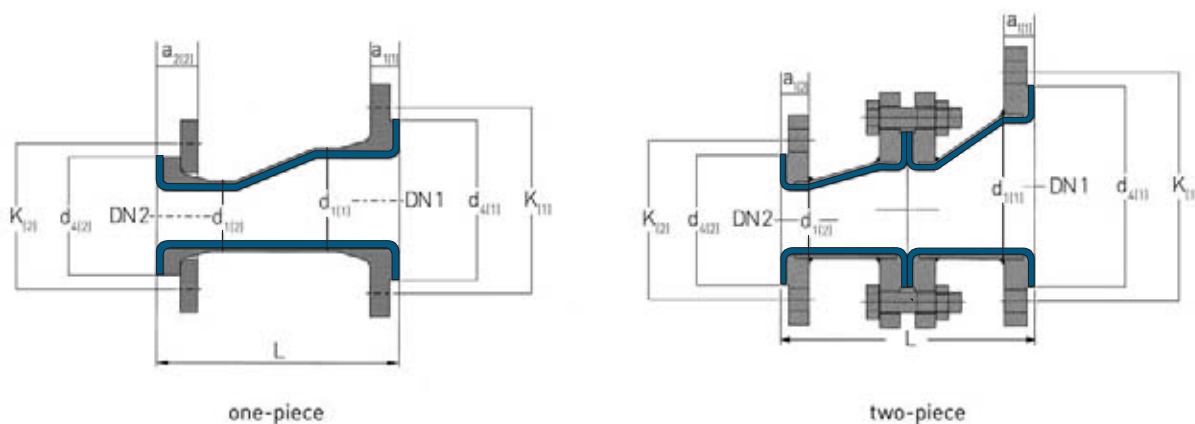

DN <sub>1</sub>	DN <sub>2</sub>	L (mm)	d <sub>1(1)</sub> (mm)	d <sub>4(1)</sub> (mm)	K <sub>1(1)</sub> (mm)	a <sub>1(1)</sub> (mm)	a <sub>2(1)</sub> (mm)	d <sub>1(2)</sub> (mm)	d <sub>4(2)</sub> (mm)	K <sub>2(1)</sub> (mm)	a <sub>1(2)</sub> (mm)	a <sub>2(2)</sub> (mm)	Lining-Materials	Screws		Wt. (ca. kg/pc.)
														(1)	(2)	
20	15	125	26,9	58	75	21,0	33,0	21,3	45	65	19,0	29,0	PTFE / PP	4xM12	4xM12	2,1
25	20	125	33,7	68	85	21,0	33,0	26,9	58	75	21,0	33,0	PTFE / PP	4xM12	4xM12	2,4
25	15		33,7	68	85	21,0	33,0	21,3	45	65	19,0	29,0	PTFE / PP	4xM12	4xM12	2,3
32	25	130	42,2	78	100	21,0	35,0	33,7	68	85	21,0	33,0	PTFE / PP	4xM16	4xM12	3,0
32	20		42,2	78	100	21,0	35,0	26,9	58	75	21,0	33,0	PTFE / PP	4xM16	4xM12	2,8
40	32	150	48,3	88	110	21,0	35,0	42,2	78	100	21,0	35,0	PTFE / PP	4xM16	4xM16	3,8
40	25	145	48,3	88	110	21,0	35,0	33,7	68	85	21,0	33,0	PTFE / PP	4xM16	4xM12	3,3
40	20	145	48,3	88	110	21,0	35,0	26,9	58	75	21,0	33,0	PFA / PP	4xM16	4xM12	3,1
50	40	165	60,3	102	125	21,0	38,0	48,3	88	110	21,0	35,0	PTFE / PP	4xM16	4xM16	4,8
50	32	165	60,3	102	125	21,0	38,0	42,2	78	100	21,0	35,0	PTFE / PP	4xM16	4xM16	4,3
50	25	160	60,3	102	125	21,0	38,0	33,7	68	85	21,0	33,0	PFA / PP	4xM16	4xM12	4,1
65	50	185	76,1	122	145	21,0	39,0	60,3	102	125	21,0	38,0	PTFE / PP	4xM16	4xM16	7,0
65	40	180	76,1	122	145	21,0	39,0	48,3	88	110	21,0	35,0	PTFE / PP	4xM16	4xM16	5,8
65	32		76,1	122	145	21,0	39,0	42,2	78	100	21,0	35,0	PFA / PP	4xM16	4xM16	6,2
80	65	190	88,9	138	160	23,0	39,0	76,1	122	145	21,0	39,0	PTFE / PP	8xM16	4xM16	7,5
80	50	190	88,9	138	160	23,0	39,0	60,3	102	125	21,0	38,0	PTFE / PP	8xM16	4xM16	6,9
80	40	185	88,9	138	160	23,0	39,0	48,3	88	110	21,0	35,0	PTFE / PP	8xM16	4xM16	6,7
80	25	185	88,9	138	160	23,0	39,0	33,7	68	85	21,0	33,0	PFA / PP	8xM16	4xM12	6,3
100	80	205	114,3	158	180	23,0	43,0	88,9	138	160	23,0	39,0	PTFE / PP	8xM16	8xM16	12,3
100	65	200	114,3	158	180	23,0	43,0	76,1	122	145	21,0	39,0	PTFE / PP	8xM16	4xM16	10,0
100	50	200	114,3	158	180	23,0	43,0	60,3	102	125	21,0	38,0	PTFE / PP	8xM16	4xM16	9,9
125	100	235	139,7	188	210	26,5	44,5	114,3	158	180	23,0	43,0	PTFE / PP	8xM16	8xM16	15,0
<b>125</b>	<b>80</b>		<b>139,7</b>	<b>188</b>	<b>210</b>	<b>26,5</b>	<b>44,5</b>	<b>88,9</b>	<b>138</b>	<b>160</b>	<b>23,0</b>	<b>39,0</b>	<b>PTFE/PFA</b>	<b>8xM16</b>	<b>8xM16</b>	<b>12,8</b>
<b>125</b>	<b>65</b>	230	<b>139,7</b>	<b>188</b>	<b>210</b>	<b>26,5</b>	<b>44,5</b>	<b>76,1</b>	<b>122</b>	<b>145</b>	<b>21,0</b>	<b>39,0</b>	<b>PTFE</b>	<b>8xM16</b>	<b>4xM16</b>	<b>15,2</b>

continued



























# Reducers excentric (PN 10)

DN <sub>1</sub>	DN <sub>2</sub>	L (mm)	d <sub>1(1)</sub> (mm)	d <sub>4(1)</sub> (mm)	K <sub>(1)</sub> (mm)	a <sub>1(1)</sub> (mm)	a <sub>2(1)</sub> (mm)	d <sub>1(2)</sub> (mm)	d <sub>4(2)</sub> (mm)	K <sub>(2)</sub> (mm)	a <sub>1(2)</sub> (mm)	a <sub>2(2)</sub> (mm)	Lining-Materials	Screws		Wt. (ca. kg/pc.)
														(1)	(2)	
150	125	250	168,3	212	240	27,0	49,0	139,7	188	210	26,5	44,5	PTFE / PP	8xM20	8xM16	20,1
150	100		168,3	212	240	27,0	49,0	114,3	158	180	23,0	43,0	PTFE / PP	8xM20	8xM16	18,3
150	80		168,3	212	240	27,0	49,0	88,9	138	160	23,0	39,0	PFA / PP	8xM20	8xM16	16,2
200	150	270	219,1	268	295	29,0	49,0	168,3	212	240	27,0	49,0	PTFE / PP	8xM20	8xM20	25,2
<b>200</b>	<b>125</b>		<b>219,1</b>	<b>268</b>	<b>295</b>	<b>29,0</b>	<b>49,0</b>	<b>139,7</b>	<b>188</b>	<b>210</b>	<b>26,5</b>	<b>44,5</b>	<b>PTFE/PP</b>	<b>8xM20</b>	<b>8xM16</b>	<b>28,0</b>
<b>200</b>	<b>100</b>		<b>219,1</b>	<b>268</b>	<b>295</b>	<b>29,0</b>	<b>49,0</b>	<b>114,3</b>	<b>158</b>	<b>180</b>	<b>23,0</b>	<b>43,0</b>	<b>PTFE/PP</b>	<b>8xM20</b>	<b>8xM16</b>	<b>22,1</b>
250	200	310	273,0	320	350	31,0	53,0	219,1	268	295	29,0	49,0	PTFE / PP	12xM20	8xM20	44,8
<b>250</b>	<b>150</b>	305	<b>273,0</b>	<b>320</b>	<b>350</b>	<b>31,0</b>	<b>53,0</b>	<b>168,3</b>	<b>212</b>	<b>240</b>	<b>27,0</b>	<b>49,0</b>	<b>PTFE/PP</b>	<b>12xM20</b>	<b>8xM20</b>	<b>38,0</b>
<b>250</b>	<b>125</b>		<b>273,0</b>	<b>320</b>	<b>350</b>	<b>31,0</b>	<b>53,0</b>	<b>139,7</b>	<b>188</b>	<b>210</b>	<b>26,5</b>	<b>44,5</b>	<b>PTFE/PP</b>	<b>12xM20</b>	<b>8xM16</b>	<b>35,5</b>
300	250	340	323,9	370	400	31,0	53,0	273,0	320	350	31,0	53,0	PTFE / PP	12xM20	12xM20	52,6
<b>300</b>	<b>200</b>	335	<b>323,9</b>	<b>370</b>	<b>400</b>	<b>31,0</b>	<b>53,0</b>	<b>219,1</b>	<b>268</b>	<b>295</b>	<b>29,0</b>	<b>49,0</b>	<b>PTFE/PP</b>	<b>12xM20</b>	<b>8xM20</b>	<b>48,0</b>
<b>300</b>	<b>150</b>	330	<b>323,9</b>	<b>370</b>	<b>400</b>	<b>31,0</b>	<b>53,0</b>	<b>168,3</b>	<b>212</b>	<b>240</b>	<b>27,0</b>	<b>49,0</b>	<b>PTFE/PP</b>	<b>12xM20</b>	<b>8xM20</b>	<b>43,4</b>
350	300	465	355,6	430	460	31,0	55,0	323,9	370	400	31,0	53,0	PTFE	16xM20	12xM20	80,0
<b>350</b>	<b>250</b>		<b>355,6</b>	<b>430</b>	<b>460</b>	<b>31,0</b>	<b>55,0</b>	<b>273,0</b>	<b>320</b>	<b>350</b>	<b>31,0</b>	<b>53,0</b>	<b>PTFE</b>	<b>16xM20</b>	<b>12xM20</b>	<b>73,6</b>
<b>350</b>	<b>200</b>		<b>355,6</b>	<b>430</b>	<b>460</b>	<b>31,0</b>	<b>55,0</b>	<b>219,1</b>	<b>268</b>	<b>295</b>	<b>29,0</b>	<b>49,0</b>	<b>PTFE</b>	<b>16xM20</b>	<b>8xM20</b>	<b>67,2</b>
400	350	495	406,4	482	515	31,0	61,0	355,6	430	460	31,0	55,0	PTFE	16xM24	16xM20	115,0
<b>400</b>	<b>300</b>		<b>406,4</b>	<b>482</b>	<b>515</b>	<b>31,0</b>	<b>61,0</b>	<b>323,9</b>	<b>370</b>	<b>400</b>	<b>31,0</b>	<b>53,0</b>	<b>PTFE</b>	<b>16xM24</b>	<b>12xM20</b>	<b>105,0</b>
<b>400</b>	<b>250</b>		<b>406,4</b>	<b>482</b>	<b>515</b>	<b>31,0</b>	<b>61,0</b>	<b>273,0</b>	<b>320</b>	<b>350</b>	<b>31,0</b>	<b>53,0</b>	<b>PTFE</b>	<b>16xM24</b>	<b>12xM20</b>	<b>95,0</b>
450	350	495	457,0	532	565	33,0	65,0	355,6	430	460	31,0	55,0	PTFE	20xM24	16xM20	148,0
<b>450</b>	<b>300</b>		<b>457,0</b>	<b>532</b>	<b>565</b>	<b>33,0</b>	<b>65,0</b>	<b>323,9</b>	<b>370</b>	<b>400</b>	<b>31,0</b>	<b>53,0</b>	<b>PTFE</b>	<b>20xM24</b>	<b>12xM20</b>	<b>140,0</b>
<b>450</b>	<b>250</b>		<b>457,0</b>	<b>532</b>	<b>565</b>	<b>33,0</b>	<b>65,0</b>	<b>273,0</b>	<b>320</b>	<b>350</b>	<b>31,0</b>	<b>53,0</b>	<b>PTFE</b>	<b>20xM24</b>	<b>12xM20</b>	<b>130,0</b>
500	400	650	508,0	585	585	33,0	69,0	406,4	482	515	31,0	61,0	PTFE	20xM24	16xM24	210,0
<b>500</b>	<b>350</b>		<b>508,0</b>	<b>585</b>	<b>585</b>	<b>33,0</b>	<b>69,0</b>	<b>355,6</b>	<b>430</b>	<b>460</b>	<b>31,0</b>	<b>55,0</b>	<b>PTFE</b>	<b>20xM24</b>	<b>16xM20</b>	<b>156,3</b>
<b>500</b>	<b>300</b>		<b>508,0</b>	<b>585</b>	<b>585</b>	<b>33,0</b>	<b>69,0</b>	<b>323,9</b>	<b>370</b>	<b>400</b>	<b>31,0</b>	<b>53,0</b>	<b>PTFE</b>	<b>20xM24</b>	<b>12xM20</b>	<b>152,1</b>



Available from stock:  
flange design fix-loose and fix-fix

- L = Total length
- d<sub>1</sub> = External diameter of the pipe
- d<sub>4</sub> = Flaring diameter
- K = Bolt circle
- a<sub>1</sub> = Length with fixed flange (standard lining)
- a<sub>2</sub> = Length with loose flange (standard lining)

The construction dimensions for DN 15 and DN 450 are not defined in DIN 2848.

DN	Standard	Lining thickness (mm)	Possible vacuum		
			23°C	100°C	230°C
25	●	3			
40	●	3			
50	●	3			
80	●	4			
100	●	4			
150	●	6			
200	●	6			
250	●	7			
300	●	7			

**Vacuum resistance:**

-  = full vacuum
-  = limited vacuum
-  = no vacuum

Please refer to the next diameter nominal if your diameter nominal is not listed.

## Valves





## Ball check valve (PN 10)

Ball check valves for horizontal or vertical installation reliably prevent the reverse flow of media. At the same time, they offer the least possible resistance in the direction of flow.



# Ball check valve (PN 10)

Lining-materials:

- PTFE (virgin or conductive)

Different lining thicknesses on request.

Other pressure rates:

- PN 16
- PN 25
- PN 40

Material: carbon steel and stainless steel

Special features: earthing studs, earthing lugs, final painting.

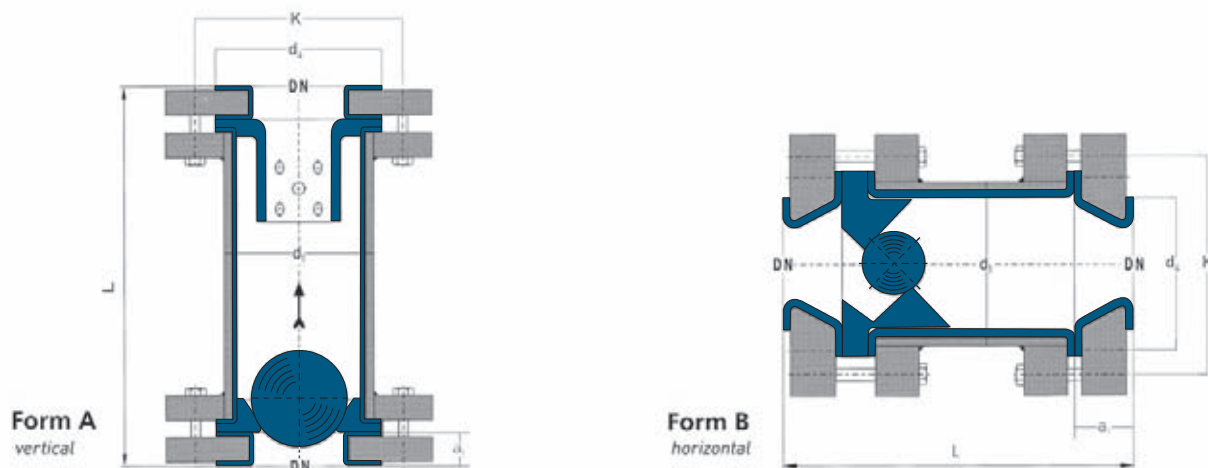

DN	L (mm)		d <sub>1</sub> (mm)	d <sub>4</sub> (mm)	K (mm)	a <sub>1</sub> (mm)	Screws	Weights (ca. kg/piece)	
	Form A	Form B						Form A	Form B
25	160	160	33,7	68	85	21,0	4xM12	5,5	10,0
32	180	180	42,4	78	100	21,0	4xM16	6,0	14,0
40	200	200	48,3	88	110	21,0	4xM16	8,5	18,5
50	230	230	60,3	102	125	21,0	4xM16	18,5	25,5
65	230	230	76,1	122	145	21,0	4xM16	22,0	28,0
80	310	310	88,9	138	160	23,0	8xM16	35,0	35,0
100	350	350	114,3	158	180	23,0	8xM16	48,0	60,0
125	325	325	139,7	188	210	26,5	8xM16	60,0	75,0
150	350	350	168,3	212	240	27,0	8xM20	90,0	100,0
200	400	400	219,1	268	295	29,0	8xM20	130,0	140,0

L = Total length

d<sub>1</sub> = External diameter of the pipe



d<sub>4</sub> = Flaring diameter

K = Bolt circle

a<sub>1</sub> = Length with fixed flange (standard lining)

DN	Standard	Lining thickness (mm)	Possible vacuum		
			23°C	100°C	230°C
25	●	3	Full	Full	Full
		4	Full	Full	Full
40	●	3	Full	Full	Limited
		4	Full	Full	Full
50	●	3	Full	Full	Limited
		4	Full	Full	Full
80	●	3	Full	Full	Limited
		4	Full	Full	Full
100	●	3	Limited	Limited	Limited
		4,5	Full	Full	Full
150	●	5	Limited	Limited	Limited
		6	Full	Full	Full
200	●	5	Limited	Limited	Limited
		6	Full	Full	Full

#### Vacuum resistance:

-  = full vacuum
-  = limited vacuum
-  = no vacuum

Please refer to the next diameter nominal if your diameter nominal is not listed.

## Bull's eye sight indicator (PN 10)

Our sight indicators – manufactured with high-quality borosilicate glasses – offer you the right view at any time.



# Bull's eye sight indicator (PN 10)

## Lining-materials:

- up to diameter nominal DN<sub>1</sub> 100 (one-piece): PFA (virgin or conductive)
- from diameter nominal DN<sub>1</sub> 125 (two-piece): PTFE (virgin or conductive)
- up to diameter nominal DN<sub>1</sub> 300 (two-piece): PP

Different lining thicknesses and flange designs on request.

## Flange design:

- fix-fix
- fix-loose
- loose-loose

## Other pressure rates:

- PN 16
- PN 25
- PN 40

Material: carbon steel and stainless steel

Special features: earthing studs, earthing lugs, flange stopper, final painting.

**Form A**

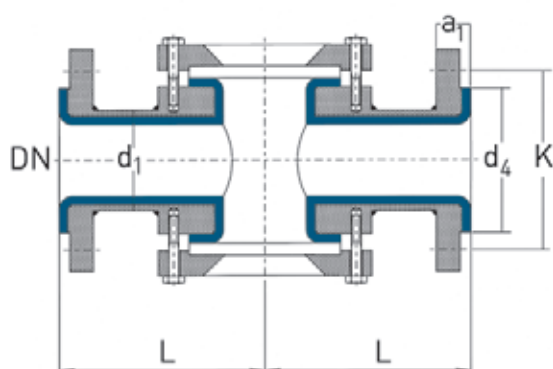

**Form B**

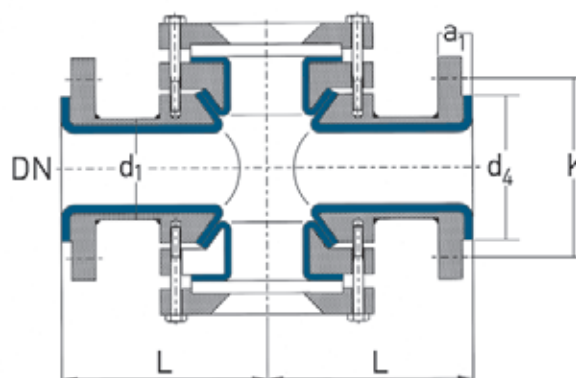

DN	L (mm)	Form	d <sub>1</sub> (mm)	d <sub>4</sub> (mm)	K (mm)	a <sub>1</sub> (mm)	a <sub>2</sub> (mm)	Screws	Weight (ca. kg/ piece)
25	110	A	33,7	68	85	21,0	33,0	4xM12	3,8
32	130	A	42,4	78	100	21,0	35,0	4xM16	4,8
40	150	A	48,3	88	110	21,0	35,0	4xM16	6,3
50	120	A	60,3	102	125	21,0	38,0	4xM16	10,0
65	140	A	76,1	122	145	21,0	39,0	4xM16	14,5
80	165	A	88,9	138	160	23,0	39,0	8xM16	23,0
100	205	A	114,3	158	180	23,0	43,0	8xM16	39,0
125	245	B	139,7	188	210	26,5	44,5	8xM16	59,0
150	285	B	168,3	212	240	27,0	49,0	8xM20	83,0
200	365	B	219,1	268	295	29,0	49,0	8xM20	122,0
250	450	B	273,0	320	350	31,0	53,0	12xM20	166,0
300	525	B	323,9	370	400	31,0	53,0	12xM20	232,0
350	600	B	355,6	430	460	31,0	55,0	16xM20	320,0
400	680	B	406,4	482	515	31,0	61,0	16xM24	380,0

L = Total length

d<sub>1</sub> = External diameter of the pipe

d<sub>4</sub> = Flaring diameter

K = Bolt circle

a<sub>1</sub> = Length with fixed flange  
(standard lining)

a<sub>2</sub> = Length with loose flange  
(standard lining)

DN	Standard	Lining thickness (mm)	Possible vacuum		
			23°C	100°C	230°C
25	●	3	☐	☐	☐
40	●	3	☐	☐	☐
50	●	3	☐	☐	☐
80	●	4	☐	☐	☐
100	●	4	☐	☐	☐
150	●	6	☐	☐	☐
200	●	6	☐	☐	☐
250	●	7	☐	☐	☐
300	●	7	☐	☐	☐

### Vacuum resistance:

- ☐ = full vacuum
- ☐ = limited vacuum
- ☐ = no vacuum

Please refer to the next diameter nominal if your diameter nominal is not listed.

## Blind flanges





## Blind Flanges (PN 10)

Any piping needs cleaning connections and also additional connections. Blind flanges close these connections during regular operation.

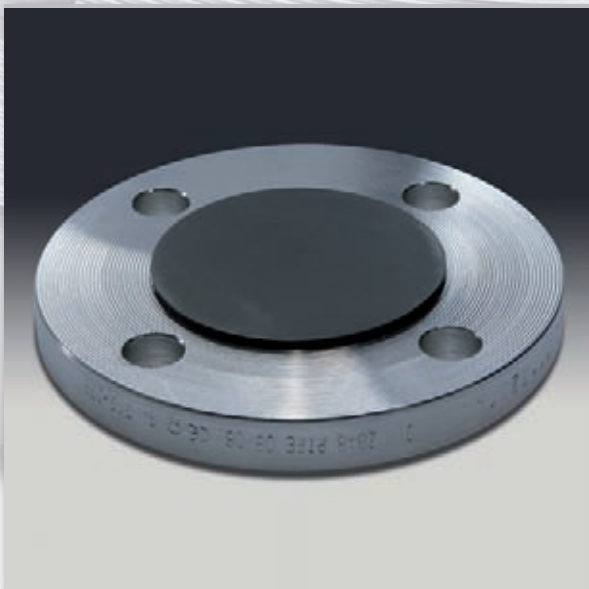
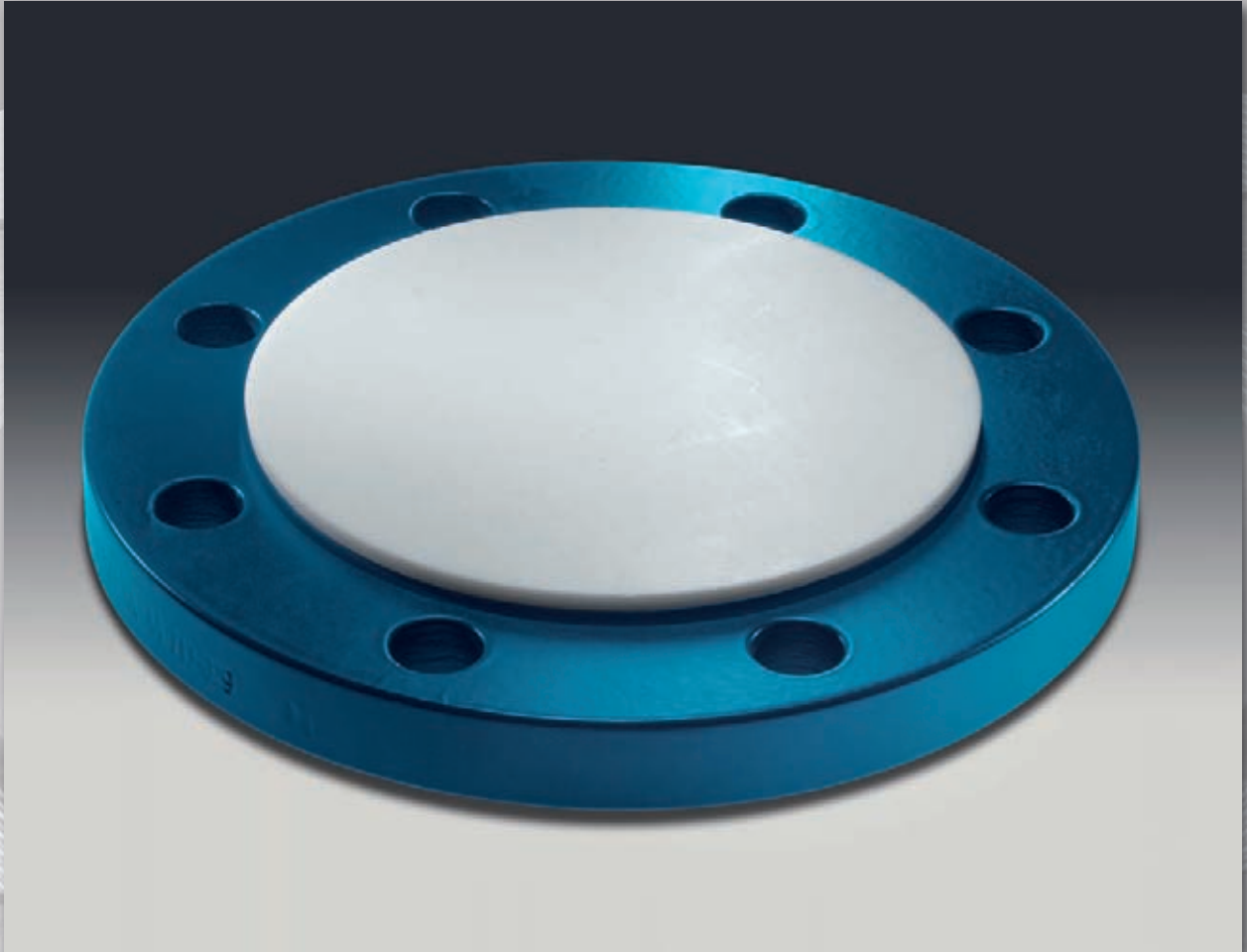

## Blind Flanges (PN 10)

Lining-materials:

- PTFE (virgin or conductive)
- PP (up to diameter nominal DN 300)

Different lining thicknesses on request.

Other pressure rates:

- PN 16
- PN 25
- PN 40

Material: carbon steel and stainless steel

Special features: earthing studs, earthing lugs, final painting.

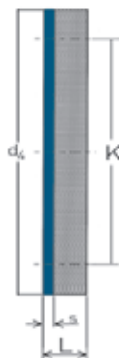

DN	L (mm)	d <sub>4</sub> (mm)	s (mm)	K (mm)	Screws	Weight (ca. kg/piece)
15	17,0	45	3	65	4 x M 12	0,8
20	19,0	58	3	75	4 x M 12	0,9
25	21,0	68	3	85	4 x M 12	1,2
32	21,0	78	3	100	4 x M 16	1,8
40	21,0	88	3	110	4 x M 16	2,1
50	21,0	102	3	125	4 x M 16	3,0
65	21,0	122	3	145	4 x M 16	4,0
80	23,5	138	3	160	8 x M 16	5,0
100	24,5	158	4,5	180	8 x M 16	6,0
125	26,5	188	5	210	8 x M 16	9,1
150	27,0	212	5	240	8 x M 20	11,8
200	29,0	268	5	295	8 x M 20	18,0
250	31,0	320	5	350	12 x M 20	26,0
300	31,0	370	5	400	12 x M 20	35,0
350	31,0	430	5	460	16 x M 20	45,0
400	32,0	482	5	515	16 x M 24	60,0
450	32,0	532	5	565	20 x M 24	70,0
500	34,0	585	5	585	20 x M 24	85,0

Available from stock:

L = Total length

d<sub>4</sub> = Flaring diameter

s = Lining thickness

K = Bolt circle

## Expansion joints





## PTFE-expansion joints, 2 convolutes (PN 10)

Our expansion joints are highly flexible and provide for the compensation of vibrations and heat-induced expansion in your production line. The possible absorption of movement is increased by the number of convolutes. Expansion joints with 2 convolutes allow the highest working pressures.

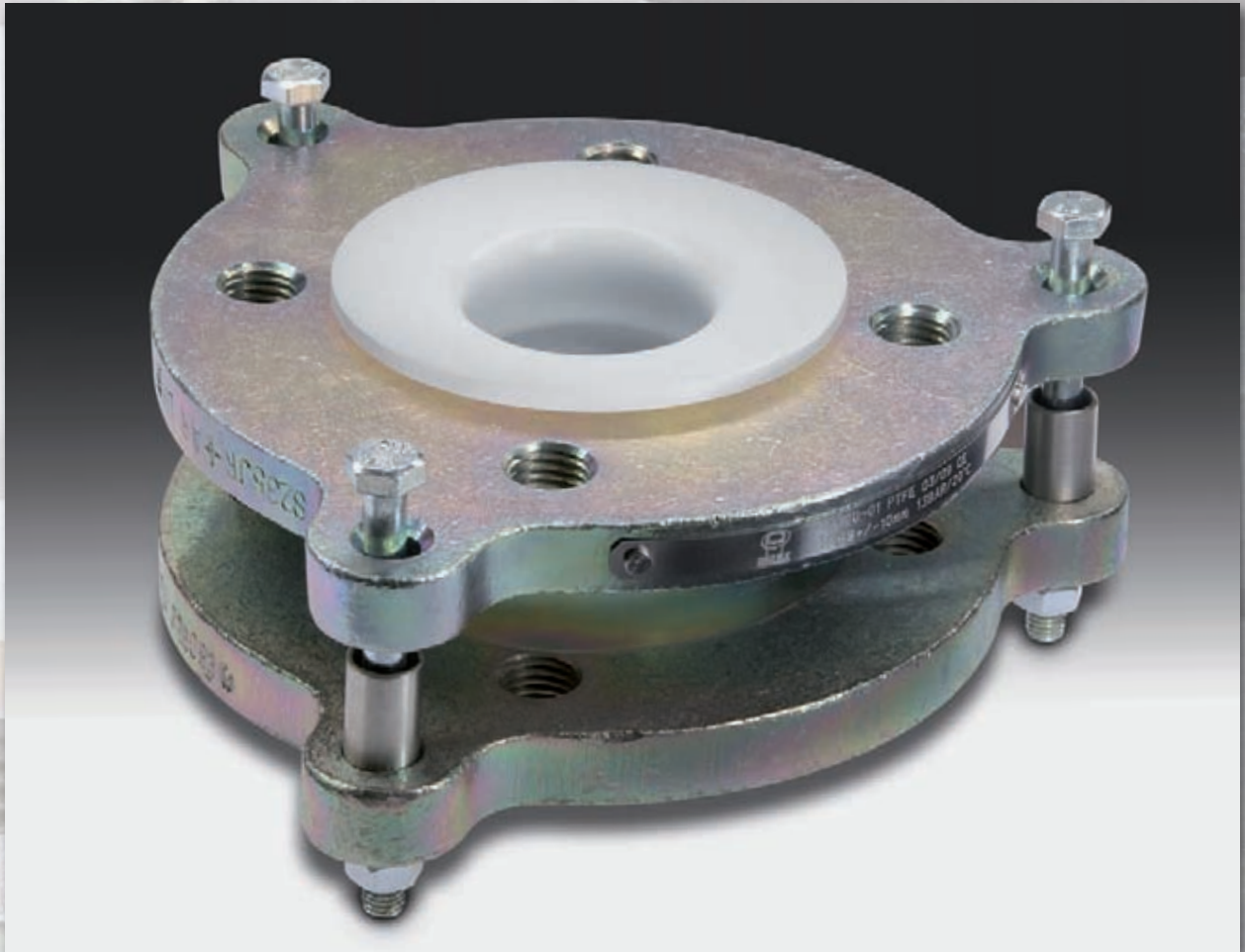

# PTFE-expansion joints, 2 convolutes (PN 10)

Lining-materials:

- PTFE (virgin or conductive)

Different lining thicknesses and flange connections upon request.

Flange design:

- loose-loose

Material: carbon steel and stainless steel

Special features: earthing studs, final painting.

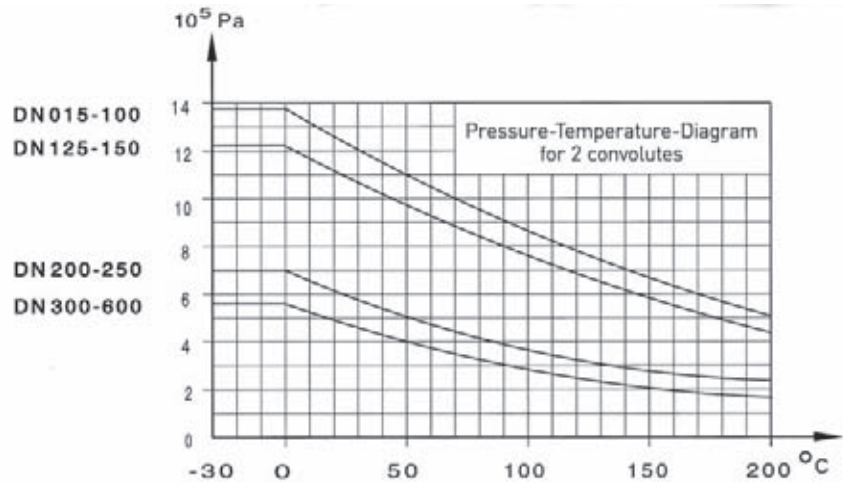
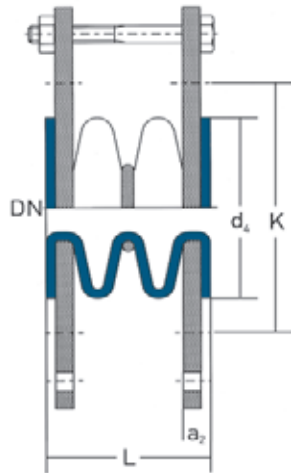

DN	L (mm)	Extension compression ± (mm)	Mis- align- ment max. (mm)	Angular deflec- tion max. °	Vaccum resistance at				d <sub>4</sub> (mm)	K (mm)	a <sub>2</sub> (mm)	Screws	Weight (ca. kg/ pc.)
					10 <sup>4</sup> Pa	max. °C	10 <sup>4</sup> Pa	max. °C					
15	35	4	2	7	0,1	200			45	65	11,00	4 x M 12	1,6
20	35	4	2	7	0,1	200			58	75	11,00	4 x M 12	1,6
25	35	6	3	7	0,1	200			68	85	11,00	4 x M 12	1,6
32	35	6	3	7	0,1	200			78	100	13,00	4 x M 16	2,0
40	35	6	3	7	0,1	200			88	110	13,00	4 x M 16	2,5
50	40	6	3	7	0,1	200			102	125	15,00	4 x M 16	3,6
65	57	9	5	7	0,1	200			122	145	15,00	4 x M 16	4,4
80	57	9	5	7	0,1	200			138	160	15,50	8 x M 16	5,2
100	67	13	6	7	0,1	200			158	180	19,00	8 x M 16	6,9
125	83	13	6	7	0,1	150			188	210	19,25	8 x M 16	11,2
150	75	13	6	7	0,1	150			212	240	23,00	8 x M 20	12,3
200	102	13	6	7	0,1	50	2,0	150	268	295	25,00	8 x M 20	20,0
250	140	15	6	7	0,7	45	3,4	100	320	350	28,00	12 x M 20	26,0
300	150	20	10	7	1,5	45	6,7	100	378	400	31,00	12 x M 20	33,0
350	160	20	10	7	1,5	45	6,7	100	438	460	32,00	16 x M 20	57,0
400	178	25	10	7	1,5	45	6,7	100	490	515	34,50	16 x M 24	72,0
450	185	25	10	7	3,4	45	7,0	100	540	565	38,50	20 x M 24	79,0
500	230	25	10	7	8,0	45	8,7	100	610	620	40,50	20 x M 24	83,0

L = Total length

d<sub>4</sub> = Flaring diameter

K = Bolt circle

a<sub>2</sub> = Length with loose flange  
(standard lining)

# PTFE-expansion joints, 2 convolutes - New design (PN 10)

## Types:

- choose type of flanges (2 or 3 ears)
- up to diameter nominal DN65: with threaded holes
- up to diameter nominal DN80: with through holes

## Flange design:

- loose-loose

Material: carbon steel and stainless steel

Special features: earthing studs, final painting.

## Lining material:

- PTFE (virgin or conductive)

Different lining thicknesses and pressure rates on request.

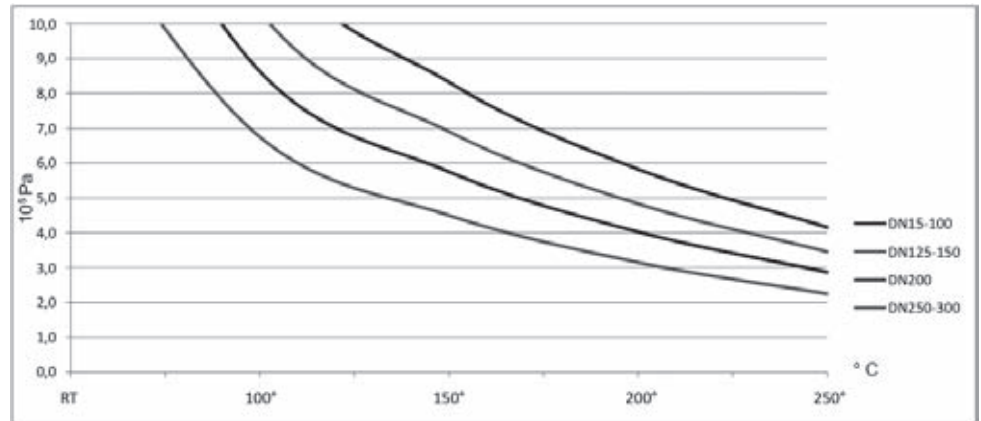
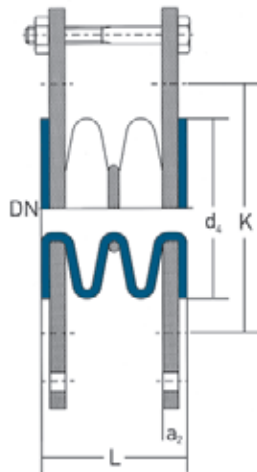

DN	L (mm)	Extension compression ± (mm)	Misa- lignment max. (mm)	Angular- deflec- tion max. °	d <sub>f</sub> (mm)	K (mm)	a <sub>2</sub> (mm)	Effectiv bellwo- cross section (cm <sup>2</sup> )	Axial spring rate 20 °C N/mm	Screws	Weight (ev. kg/ pièce.)
15	54	6	3	7	45	65	11	24	27	4 x M 12	1,7
20	54	6	3	7	58	75	11	24	27	4 x M 12	1,7
25	54	6	3	7	68	85	11	24	27	4 x M 12	1,7
32	56	6	3	7	78	100	13	33	57	4 x M 16	2,1
40	56	6	3	7	88	110	13	40	66	4 x M 16	2,6
50	68	10	3	7	102	125	15	55	86	4 x M 16	3,8
65	78	12	5	7	122	145	15	85	122	4 x M 16	4,6
80	88	15	5	7	138	160	15,5	113	147	8 x M 16	5,2
100	88	15	6	7	158	180	19	158	161	8 x M 16	6,9
125	95	15	6	7	188	210	19,25	222	177	8 x M 16	11,3
150	105	15	6	7	212	240	23	299	168	8 x M 20	12,6
200	110	15	6	7	268	295	25	483	185	8 x M 20	20,8
250	128	20	6	7	320	350	28	731	174	12 x M 20	26,7
300	140	20	10	7	378	400	31	973	161	12 x M 20	34,7

L = Total length

d<sub>f</sub> = Flaring diameter

K = Bolt circle

a<sub>2</sub> = Length with loose flange  
(standard lining)

# PTFE-expansion joints, 2 convolutes - New design (PN 10)

DN	Over pressure resistance 10 <sup>5</sup> Pa at				Vaccum resistance 10 <sup>5</sup> Pa at			
	20°C	100°C	150°C	200 °C	20°C	100°C	150°C	200 °C
15	10	10	8,3	5,8	-1	-1	-1	-1
20	10	10	8,3	5,8	-1	-1	-1	-1
25	10	10	8,3	5,8	-1	-1	-1	-1
32	10	10	8,3	5,8	-1	-1	-1	-1
40	10	10	8,3	5,8	-1	-1	-1	-1
50	10	10	8,3	5,8	-1	-1	-1	-1
65	10	10	8,3	5,8	-1	-1	-1	-1
80	10	10	8,3	5,8	-1	-1	-1	-1
100	10	10	8,3	5,8	-1	-1	-1	-1
125	10	9,2	6,9	4,8	-1	-1	-1	-0,80
150	10	9,2	6,9	4,8	-1	-1	-1	-0,80
200	10	7,7	5,8	4	-1	-1	-1	-0,70
250	10	6	4,5	3,2	-1	-1	-0,80	-0,55
300	10	6	4,5	3,2	-1	-1	-0,65	-0,45

## PTFE-expansion joints, 3 convolutes (PN 10)

Our expansion joints are highly flexible and provide for the compensation of vibrations and heat-induced expansion in your production line. The possible absorption of movement is increased by the number of convolutes. Expansion joints with 3 convolutes are the standard solution for most of the applications.

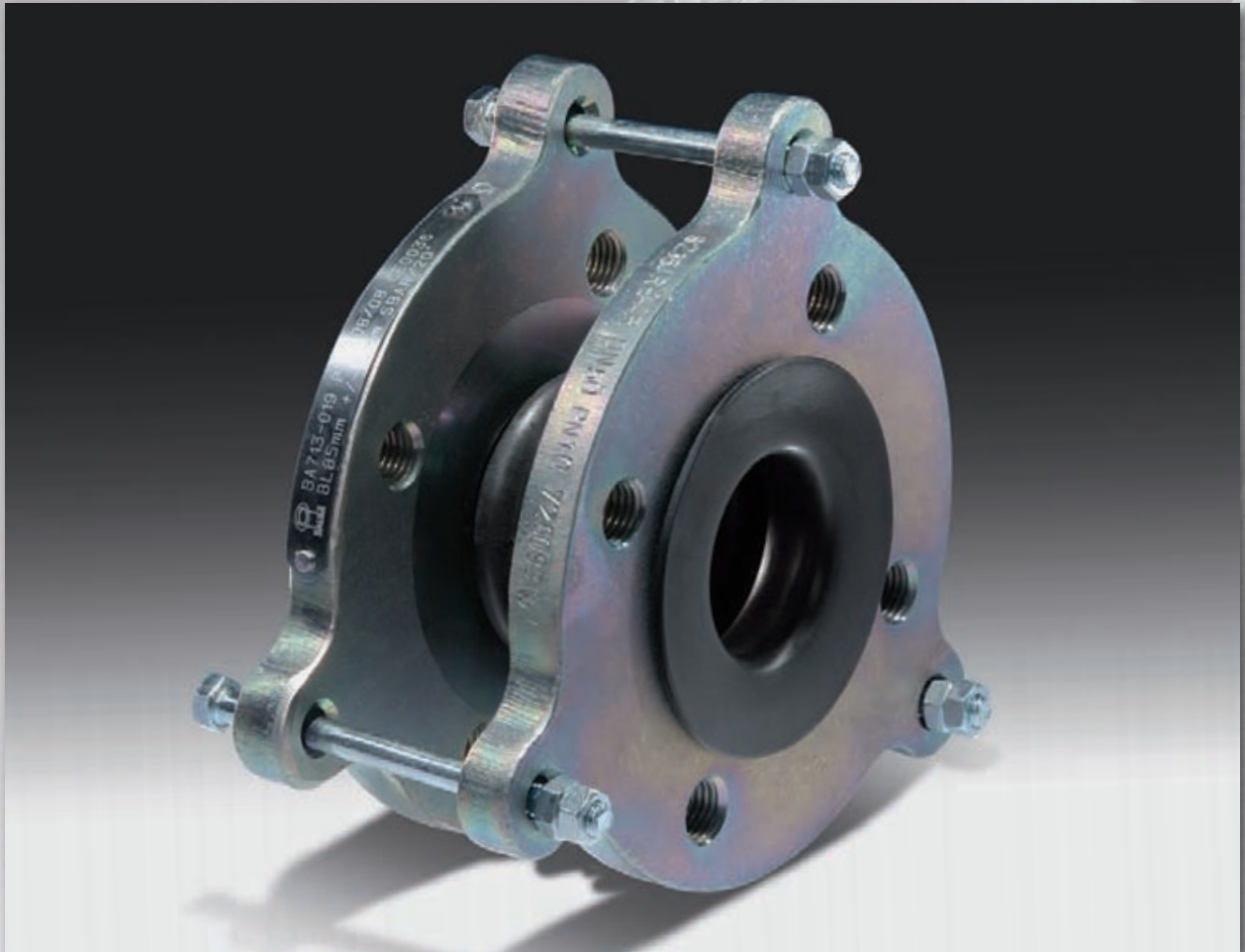



# PTFE-expansion joints, 3 convolutes (PN 10)

Lining-materials:

- PTFE (virgin or conductive)

Different lining thicknesses and pressure rates on request.

Flange design:

- loose-loose

Material: carbon steel and stainless steel

Special features: earthing studs, final painting.

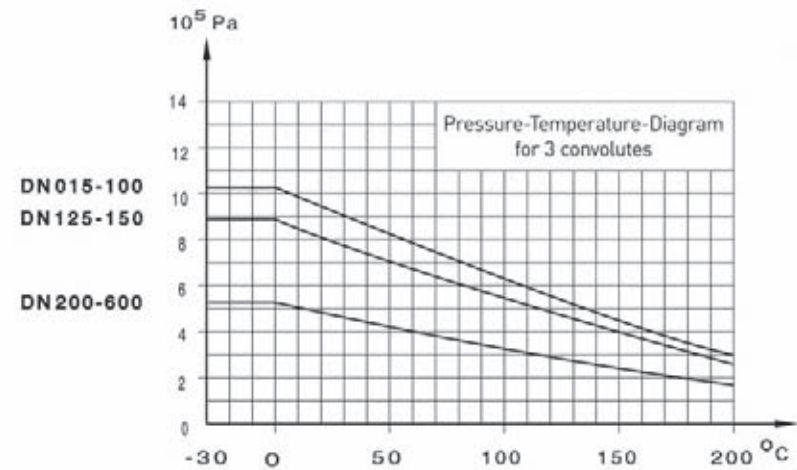
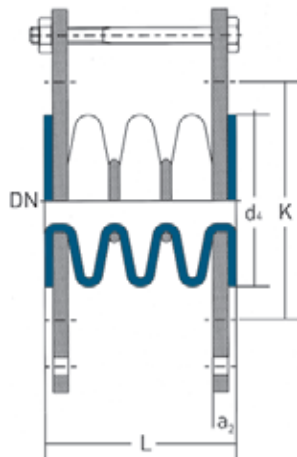

DN	L (mm)	Extension compression ± (mm)	Misa- alignment max. (mm)	Angular deflec- tion max. °	Vaccum resistance at				d <sub>4</sub> (mm)	K (mm)	a <sub>2</sub> (mm)	Screws	Weight (ca. kg/ St.)
					10 <sup>4</sup> Pa	max. °C	10 <sup>4</sup> Pa	max. °C					
15	46	6	4	14	-1	200			45	65	11,00	4 x M 12	1,7
20	46	6	4	14	-1	200			58	75	11,00	4 x M 12	1,7
25	46	13	6	14	-1	200			68	85	11,00	4 x M 12	1,7
32	46	13	6	14	-1	200			78	100	13,00	4 x M 16	2,1
40	46	13	6	14	-1	200			88	110	13,00	4 x M 16	2,6
50	56	15	9	14	-1	200			102	125	15,00	4 x M 16	3,8
65	77	19	9	14	-1	200			122	145	15,00	4 x M 16	4,6
80	77	25	13	14	-1	200			138	160	15,50	8 x M 16	5,3
100	91	25	13	14	-1	200			158	180	19,00	8 x M 16	7,0
125	111	25	14	14	-1	150			188	210	19,25	8 x M 16	11,4
150	101	28	14	14	-1	150			212	240	23,00	8 x M 20	12,7
200	137	28	14	14	-1	50	-0,8	150	268	295	25,00	8 x M 20	21,0
250	200	30	14	14	-0,93	45	-0,66	100	320	350	28,00	12 x M 20	27,0
300	196	30	15	14	-0,85	45	-0,33	100	378	400	31,00	12 x M 20	35,0
350	215	32	18	14	-0,85	45	-0,33	100	438	460	32,00	16 x M 20	60,0
400	233	35	20	14	-0,85	45	-0,33	100	490	515	34,50	16 x M 24	75,0
450	280	30	20	14	-0,66	45	-0,3	100	540	565	38,50	20 x M 24	91,0
500	327	30	25	14	---	---	-0,13	100	610	620	40,50	20 x M 24	110,0

L = Total length

d<sub>4</sub> = Flaring diameter

K = Bolt circle

a<sub>2</sub> = Length with loose flange  
(standard lining)

# PTFE-expansion joints, 3 convolutes - New design (PN 10)

## Execution:

- choose type of flanges (2 or 3 ears)
- up to diameter nominal DN65: with threaded holes
- up to diameter nominal DN80: with through holes

## Lining material:

- PTFE (virgin or conductive)

Different lining thicknesses and pressure rates on request.

## Flange design:

- loose-loose

Material: carbon steel and stainless steel

Special features: earthing studs, final painting.

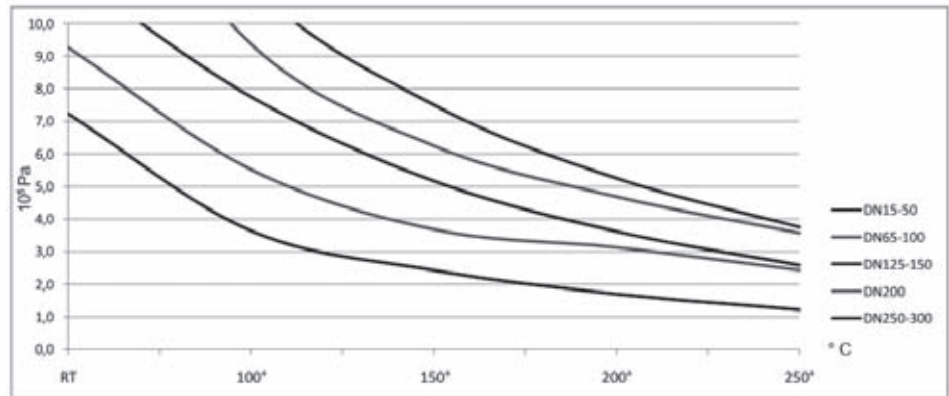
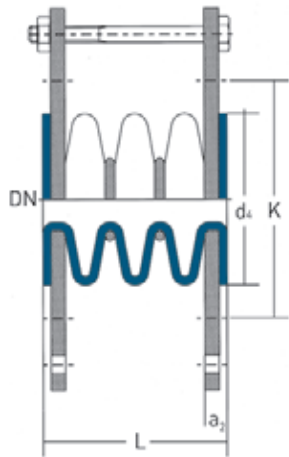

DN	L (mm)	Extension compression ± (mm)	Misa- lignment max. (mm)	Angular- deflec- tion max. °	d <sub>4</sub> (mm)	K (mm)	a <sub>2</sub> (mm)	Effectiv bellow- cross section (cm <sup>2</sup> )	Axial spring rate 20 °C N/mm	Screws	Weight (ca. kg/ St.)
15	70	10	6	14	45	65	11	24	18	4 x M 12	1,9
20	70	10	6	14	58	75	11	24	18	4 x M 12	1,9
25	70	10	6	14	68	85	11	24	18	4 x M 12	1,9
32	75	10	6	14	78	100	13	33	38	4 x M 16	2,3
40	80	15	6	14	88	110	13	40	44	4 x M 16	2,9
50	85	15	9	14	102	125	15	55	57	4 x M 16	4,2
65	100	20	9	14	122	145	15	85	81	4 x M 16	5,1
80	110	20	13	14	138	160	15,5	113	98	8 x M 16	5,8
100	110	25	13	14	158	180	19	158	107	8 x M 16	7,7
125	120	25	14	14	188	210	19,25	222	118	8 x M 16	12,5
150	130	25	14	14	212	240	23	299	112	8 x M 20	14,0
200	140	30	14	14	268	295	25	483	123	8 x M 20	23,1
250	165	30	14	14	320	350	28	731	116	12 x M 20	29,7
300	175	30	15	14	378	400	31	973	107	12 x M 20	38,5

continued

L = Total length  
d<sub>4</sub> = Flaring diameter  
K = Bolt circle  
a<sub>2</sub> = Length with loose flange  
(standard lining)

## PTFE-expansion joints, 3 convolutes - New design (PN 10)

DN	Over pressure resistance 10 <sup>5</sup> Pa at				Vaccum resistance 10 <sup>5</sup> Pa at			
	20°C	100°C	150°C	200 °C	20°C	100°C	150°C	200 °C
15	10	10	7,5	5,3	-1	-1	-1	-1
20	10	10	7,5	5,3	-1	-1	-1	-1
25	10	10	7,5	5,3	-1	-1	-1	-1
32	10	10	7,5	5,3	-1	-1	-1	-1
40	10	10	7,5	5,3	-1	-1	-1	-1
50	10	10	7,5	5,3	-1	-1	-1	-1
65	10	8,3	6,3	4,7	-1	-1	-1	-1
80	10	8,3	6,3	4,7	-1	-1	-1	-1
100	10	8,3	6,3	4,7	-1	-1	-1	-1
125	10	6,9	5,2	3,6	-1	-1	-1	-0,80
150	10	6,9	5,2	3,6	-1	-1	-1	-0,80
200	9,3	4,9	3,7	3,1	-1	-1	-0,80	-0,55
250	7,2	3,2	2,4	1,7	-1	-1	-0,70	-0,45
300	7,2	3,2	2,4	1,7	-1	-1	-0,50	-0,35



## PTFE-expansion joints, 5 convolutes (PN 10)

Our expansion joints are highly flexible and provide for the compensation of vibrations and heat-induced expansion in your production line. Expansion joints with 5 convolutes allow the maximum absorption of movement.



# PTFE-expansion joints, 5 convolutes (PN 10)

Lining-materials:

- PTFE (virgin or conductive)

Different lining thicknesses and flange connections upon request.

Flange design:

- loose-loose

Material: carbon steel and stainless steel

Special features: earthing studs, final painting.

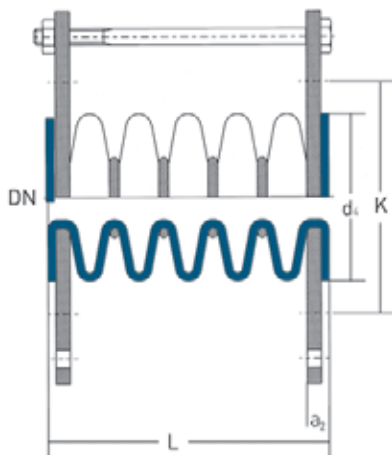

DN 015-500

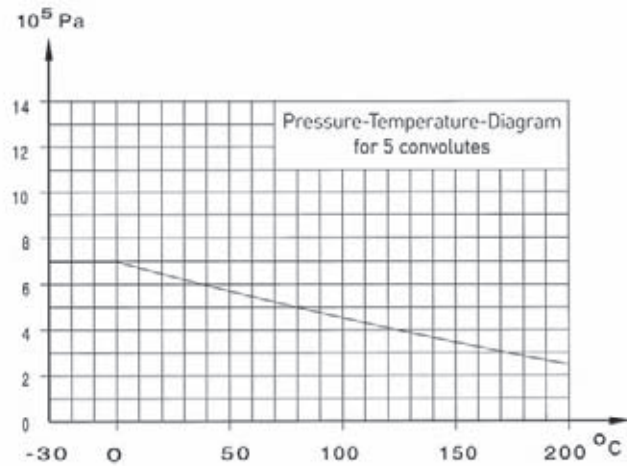

DN	L (mm)	Extension compression ± (mm)	Mis- align- ment max. (mm)	Angular deflec- tion max. °	Vaccum resistance at				d <sub>4</sub> (mm)	K (mm)	a <sub>2</sub> (mm)	Screws	Weight (ca. kg/ pc.)
					10 <sup>4</sup> Pa	max. °C	10 <sup>4</sup> Pa	max. °C					
15	68	8	5	20	confer with us				45	65	11,00	4 x M 12	1,9
20	68	8	5	20					58	75	11,00	4 x M 12	1,9
25	68	8	12	20					68	85	11,00	4 x M 12	1,9
32	68	8	12	20					78	100	13,00	4 x M 16	2,2
40	80	13	12	20					88	110	13,00	4 x M 16	2,7
50	88	19	12	20					102	125	15,00	4 x M 16	4,3
65	113	25	13	20					122	145	15,00	4 x M 16	5,0
80	113	25	16	20					138	160	15,50	8 x M 16	5,4
100	139	25	16	20					158	180	19,00	8 x M 16	7,1
125	167	32	16	20					188	210	19,25	8 x M 16	12,0
150	153	32	16	20					212	240	23,00	8 x M 20	14,2
200	207	32	16	20					268	295	25,00	8 x M 20	22,0
250	300	32	16	20					320	350	28,00	12 x M 20	29,0
300	288	35	16	20					378	400	31,00	12 x M 20	40,0
350	325	35	18	20					438	460	32,00	16 x M 20	65,0
400	343	40	25	20					490	515	34,50	16 x M 24	81,0
450	470	40	25	20					540	565	38,50	20 x M 24	97,0
500	520	40	25	20					610	620	40,50	20 x M 24	110,0

L = Total length

d<sub>4</sub> = Flaring diameter

K = Bolt circle

a<sub>2</sub> = Length with loose flange  
(standard lining)

## PTFE-lined stainless steel expansion joint (PN 10)

In case of high pressures and high temperatures, our stainless steel expansion joints are the right choice for your pipes. Stainless steel expansion joints are the most stable expansion joints.

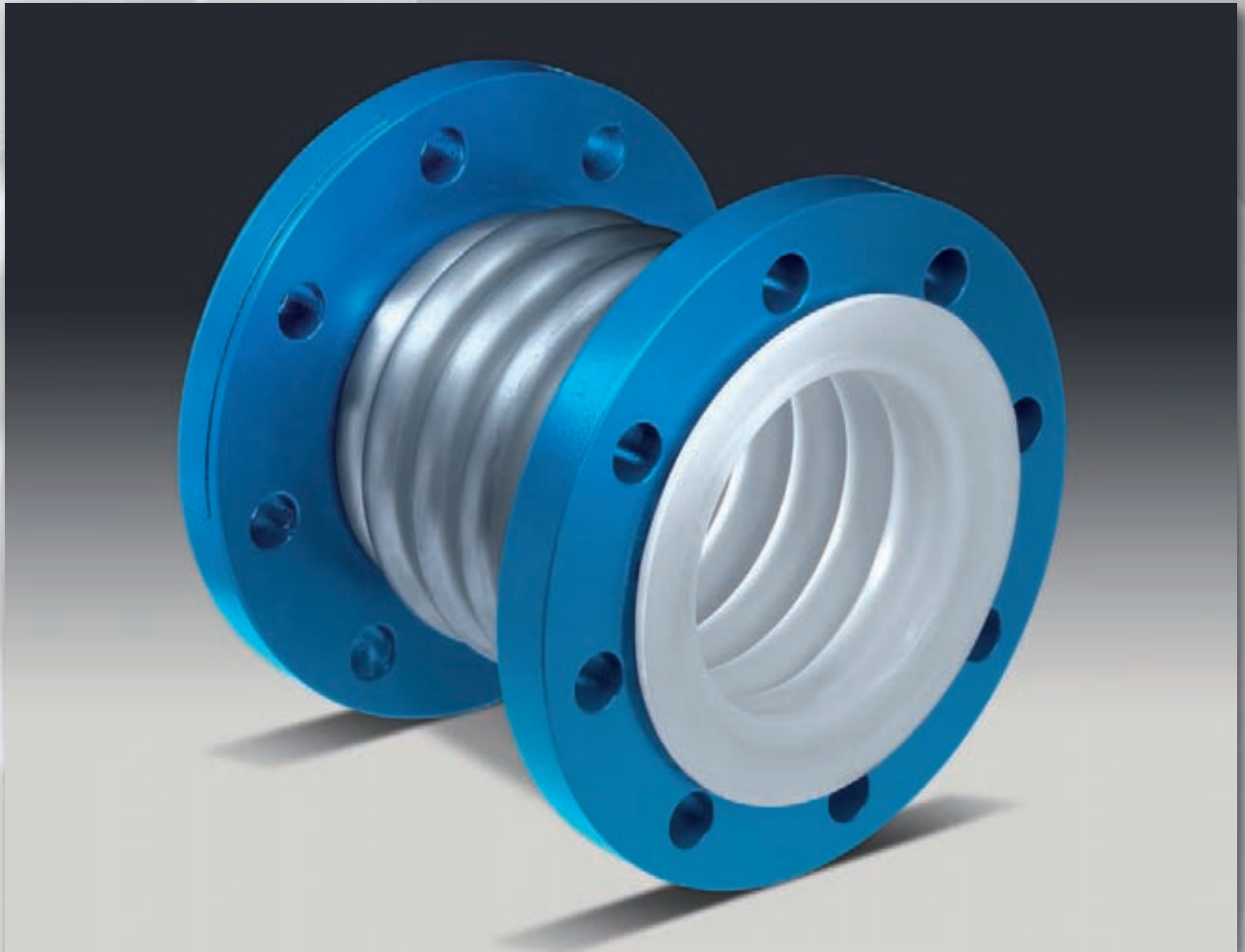

## PTFE-lined stainless steel expansion joint (PN 10)

Lining-materials:

- PTFE (virgin or conductive)

Different lining thicknesses and flange connections upon request.

Flange design:

- loose-loose

Other pressure rates:

- PN 16

Material of bellow: stainless steel (1.4541)

Material of flanges: stainless steel (1.0038, 1.4541 or 1.4571)

Special features: earthing studs, final painting.



DN	L (mm)	Extension compression ± (mm)	Spring rate (N/mm)	Vaccum resistance 10 <sup>5</sup> Pa at		d <sub>4</sub>	Flange design	Screws	Weight (ca. kg/pc.)
				23 °C	160 °C				
32	145	9	260	0,15	0,30	70	Form 1	4 x M16	4,0
32	220	18	130	0,15	0,30	70	Form 1	4 x M16	4,0
40	155	11	272	0,15	0,30	80	Form 1	4 x M16	5,0
40	240	22	136	0,15	0,30	80	Form 1	4 x M16	5,0
50	177	13	276	0,15	0,30	92	Form 1	4 x M16	6,0
50	292	27	195	0,15	0,30	92	Form 1	4 x M16	6,0
65	191	17	234	0,15	0,30	115	Form 1	4 x M16	7,0
65	287	32	173	0,15	0,30	115	Form 1	4 x M16	7,5
80	185	20	220	0,15	0,30	126	Form 1	8 x M16	7,5
80	275	35	178	0,15	0,30	126	Form 1	8 x M16	8,5
100	178	20	365	0,15	0,30	153	Form 1	8 x M16	10,0
100	266	40	183	0,15	0,30	153	Form 1	8 x M16	11,5
125	221	29	290	0,25	0,40	185	Form 1	8 x M16	13,0
125	363	50	290	0,25	0,40	185	Form 1	8 x M16	15,0
150	248	30	560	0,25	0,40	208	Form 2	8 x M20	17,0
150	388	60	280	0,25	0,40	208	Form 2	8 x M20	20,0
200	246	42	412	0,35	0,50	264	Form 2	8 x M20	24,0
200	418	78	335	0,35	0,50	264	Form 2	8 x M20	30,0
250	243	44	525	0,40	0,60	325	Form 2	12 x M20	32,0
250	392	81	269	0,40	0,60	325	Form 2	12 x M20	35,0
300	287	55	480	0,50	0,75	375	Form 2	12 x M20	37,0
300	429	95	352	0,50	0,75	375	Form 2	12 x M20	43,0
350	289	60	460	0,50	0,75	420	Form 1	16 x M20	51,0
350	396	92	378	0,50	0,75	420	Form 1	16 x M20	57,0
400	283	52	713	0,70	0,90	475	Form 1	16 x M24	68,0
400	421	104	357	0,70	0,90	475	Form 1	16 x M24	75,0
450	320	70	548	0,70	0,90	530	Form 1	20 x M24	76,0
450	517	130	430	0,70	0,90	530	Form 1	20 x M24	97,0
500	303	56	955			580	Form 1	20 x M24	97,0
500	493	126	425			580	Form 1	20 x M24	113,0
600	324	70	548			680	Form 2	20 x M27	118,0
600	464	126	305			680	Form 2	20 x M27	130,0

L = Total length

d<sub>4</sub> = Flaring diameter



## PTFE-Vacuum expansion joint (PN 10)

Vacuum expansion joints allow full vacuum, also in case of large nominal widths and high temperatures.

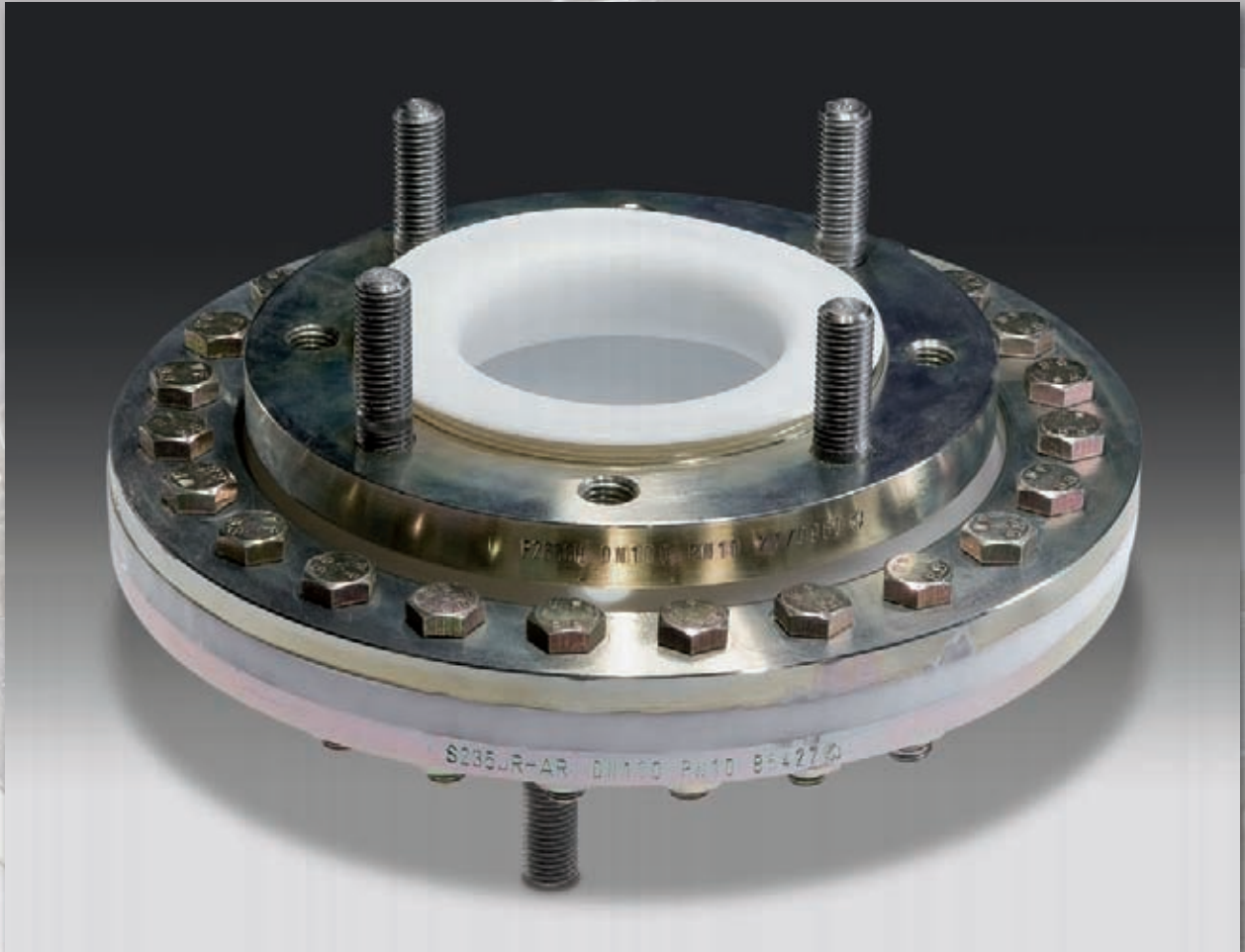

S235JR-AR DN100 PN10 854270

## PTFE-Vacuum expansion joint (PN 10)

Lining-materials:

- PTFE (virgin or conductive)

Different lining thicknesses and flange connections upon request.

Flange design:

- loose-loose

Material: carbon steel and stainless steel

Special features: earthing studs, final painting.

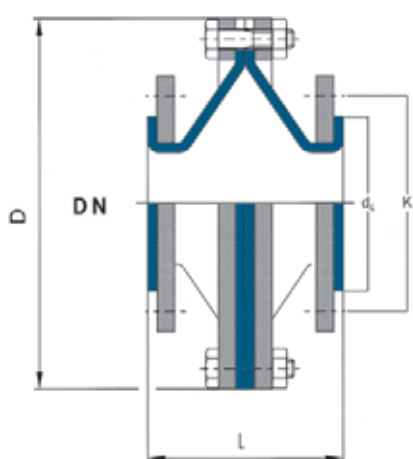

pressure  
bar

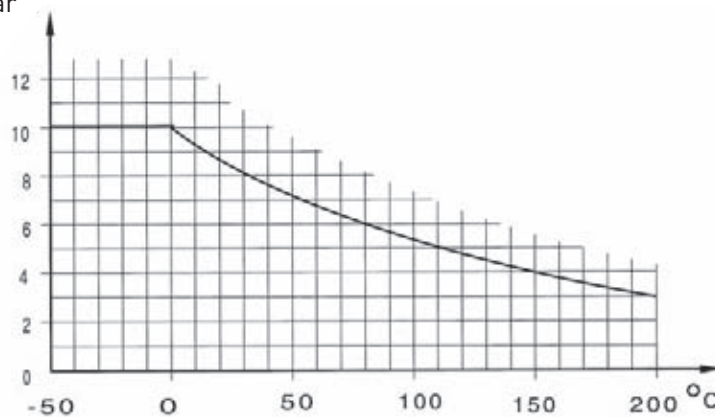

DN	L (mm)	Extension compression ± (mm)	D (mm)	d <sub>4</sub>	K	Screws	Weight (ca. kg/pc.)
100	95	10	185	158	180	8 x M16	11,0
150	100	15	350	212	240	8 x M20	17,0
200	105	15	410	268	295	8 x M20	24,0
250	110	18	465	320	350	12 x M20	37,0
300	115	18	520	378	400	12 x M20	40,0
350	120	18	590	438	460	16 x M20	51,0
400	135	20	670	490	515	16 x M24	62,0
450	150	20	695	540	565	20 x M24	90,0
500	150	20	770	610	620	20 x M25	108,0

L = Total length  
D = External diameter  
d<sub>4</sub> = Flaring diameter  
K = Bolt circle

## Nozzle liners and dip pipes





## PTFE-Nozzle liner (PN 10)

PTFE nozzle liners protect tank walls during the filling with corrosive media.



## PTFE-Nozzle liner (PN 10)

Lining-materials:

- PTFE (virgin or conductive)

Different lining thicknesses on request.

Other pressure rates:

- PN 16
- PN 25
- PN 40

Different external diameter of the pipe and flaring diameter on request.

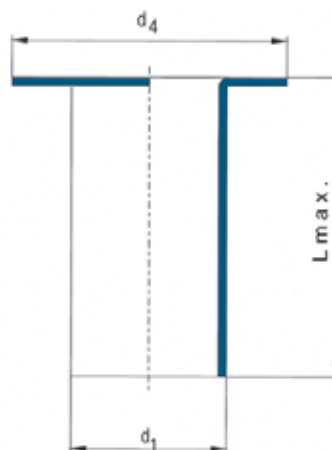

DN	L <sub>max.</sub> (mm)	d <sub>1</sub> (mm)	Allo- wance ± (mm)	d <sub>4</sub> (mm)	Weight (ca. kg/m)
25	6000	21	2	62	0,2
32	6000	29	2	78	0,3
40	6000	34	2	88	0,4
50	6000	46	3	102	0,6
65	6000	59	4	122	0,9
80	6000	74	4	138	1,2
100	6000	94	5	158	1,6
125	6000	120	5	188	2,0
150	6000	144	5	212	2,1
200	6000	186	6	268	3,8
250	3000	231	10	320	4,2
300	3000	288	10	370	6,3
350	3000	315	10	430	7,1
400	2000	370	10	482	7,9
500	2000	470	10	585	18,5

L = Total length

d<sub>1</sub> = External diameter of the pipe

d<sub>4</sub> = Flaring diameter

## PTFE-Lined Dip Pipe (PN 10)

Dip pipes allow the precise feeding of corrosive media into tanks. Nozzle heads additionally offer the possibility of a directed dispersion of the medium.

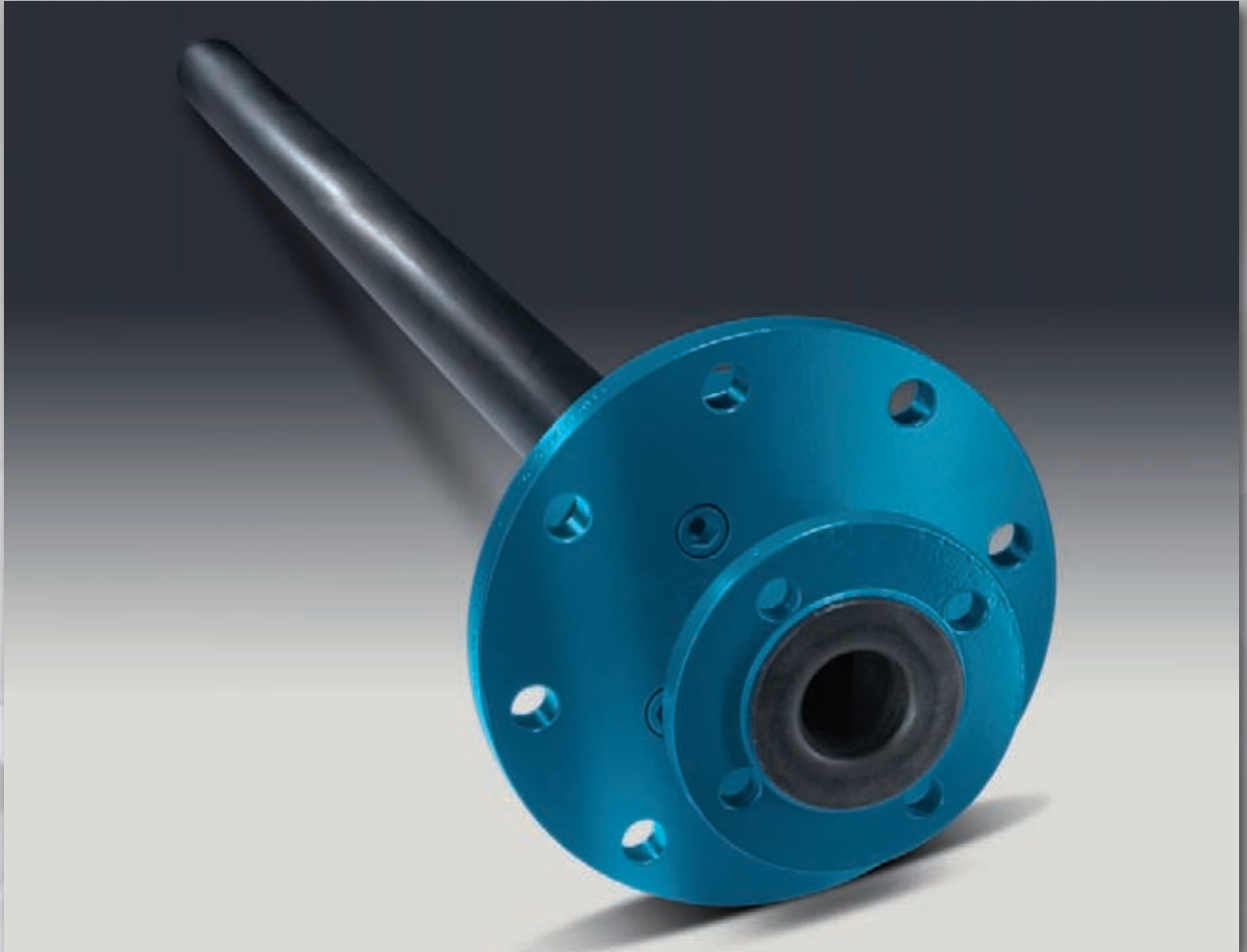

# PTFE-Lined Dip Pipe (PN 10)

Lining-materials:

- PTFE (virgin or conductive)

Different lining thicknesses on request.

Types:

- welded
- seamless

Other pressure rates:

- PN 16
- PN 25
- PN 40

Material: carbon steel and stainless steel

Special features: earthing studs, earthing lugs, flange stopper, final painting, with nozzle head, bended type.

Please indicate the type of lining (welded/seamless).

## for calm vessels (standard type)

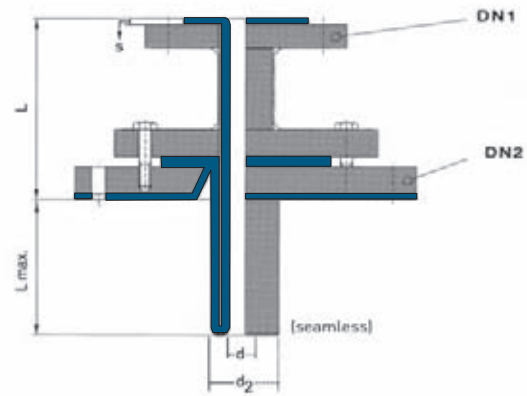
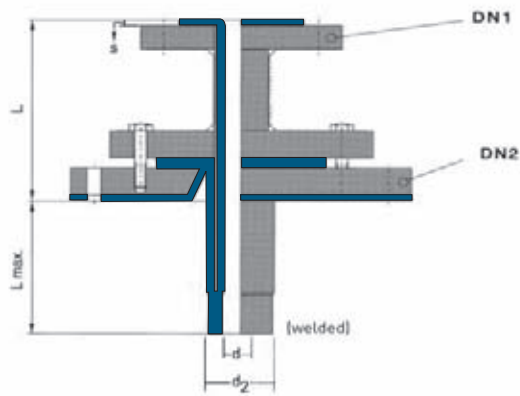

DN <sub>1</sub>	Steel pipe Outer diam. x wall	DN <sub>2</sub>	L <sub>Kopf</sub> (mm)	L <sub>max.</sub> (mm)		s (mm)	d (mm)	d <sub>2</sub> (mm)
				welded	seamless			
25	33,7 x 2,6	Please indicate with your order	150	5500	2800	3,5	21,5	40,7
32	42,4 x 2,6		150	5500	2800	4	29,2	50,4
40	48,3 x 2,6		150	5500	2800	4	35,1	56,3
50	60,3 x 2,9		150	5500	2800	4	46,5	68,3
65	76,1 x 2,9		150	5500	2800	4	62,3	84,1
80	88,9 x 3,2		150	5500	2800	4	74,5	96,9
100	114,3 x 3,6		150	5000	2500	5	97,1	124,3
125	139,7 x 4,0		150	5000	2500	4,5	122,7	148,7
150	168,3 x 4,5		150	5000	2500	5	149,3	178,3
200	219,1 x 6,3		150	4000	2000	5	196,5	229,1
250	273,0 x 6,3		150	3000	1500	6	248,4	285,0
300	323,9 x 7,1		150	3000	1500	6	297,7	335,9
350	355,6 x 8,0		150	2000	-----	6	327,6	367,6
400	406,4 x 8,8		150	2000	-----	5	378,8	416,4

L = Total length

s = Lining thickness

d = Internal diameter of the pipe

d<sub>2</sub> = External diameter of the pipe

# PTFE-Lined Dip Pipe (PN 10)

Lining-materials:

- PTFE (virgin or conductive)

Different lining thicknesses on request.

Types:

- welded
- seamless

Other pressure rates:

- PN 16
- PN 25
- PN 40

Material: carbon steel and stainless steel

Special features: earthing studs, earthing lugs, flange stopper, final painting, with nozzle head, bended type.

Please indicate the type of lining (welded/seamless).

## for agitated vessels (reinforced)

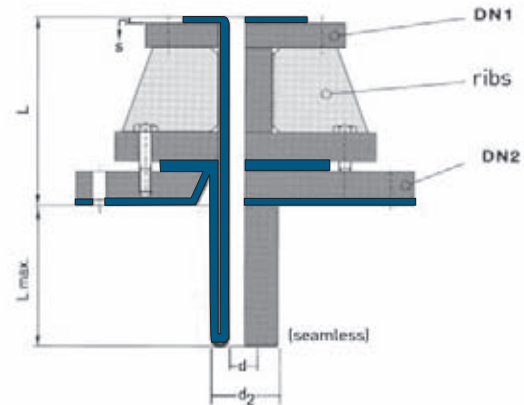
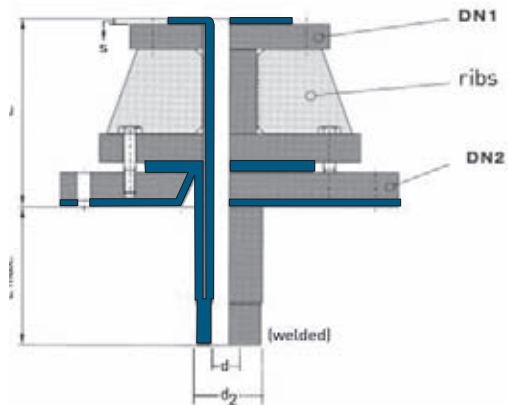

DN <sub>1</sub>	Steel pipe Outer diam. x wall	DN <sub>2</sub>	L <sub>Kopf</sub> (mm)	L <sub>max.</sub> (mm)		s (mm)	d (mm)	d <sub>2</sub> (mm)
				welded	seamless			
25	33,7 x 4,0	Please indicate with your order	150	5000	---	3,5	18,7	40,7
32	42,4 x 6,3		150	5000	---	4	21,8	50,4
40	48,3 x 6,3		150	5000	---	4	27,7	56,3
50	60,3 x 8,0		150	5000	---	4	36,3	68,3
65	76,1 x 10,0		150	5000	---	4	48,1	84,1
80	88,9 x 10,0		150	5000	---	4	60,9	96,9
100	114,3 x 10,0		150	4000	---	5	84,3	124,3
125	139,7 x 10,0		150	4000	---	4,5	110,7	148,7
150	168,3 x 16,0		150	4000	---	5	126,3	178,3
200	219,1 x 16,0		150	4000	---	5	177,1	229,1
250	273,0 x 16,0		150	3000	---	6	229,0	285,0
300	323,9 x 16,0		150	3000	---	6	279,9	335,9

L = Total length  
s = Lining thickness  
d = Internal diameter of the pipe  
d<sub>2</sub> = External diameter of the pipe

## Hoses

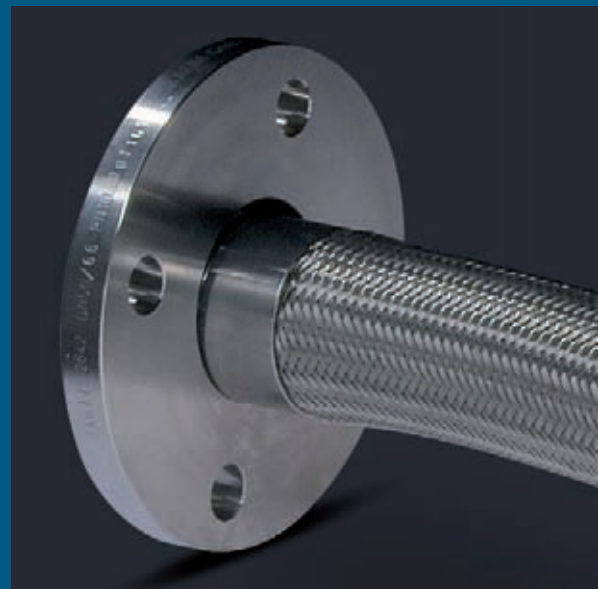



## **PTFE chemical transfer hose-smooth bore with stripwound house (PN 10)**

The stripwound hose is a metal protection hose with a high mechanical strength, adequate for higher pressures; the hose is torsion-proofed, high tensile and it has a straight PTFE liner.





# PTFE chemical transfer hose-smooth bore with stripwound house (PN 10)

Lining-materials:

- PTFE (virgin or conductive)

Different lining thicknesses on request.

Flange design:

- fix-fix
- fix-loose
- loose-loose

Other pressure rates:

- PN 16
- PN 25
- PN 40

Material: carbon steel and stainless steel

Special features: earthing studs, flange stopper, final painting.

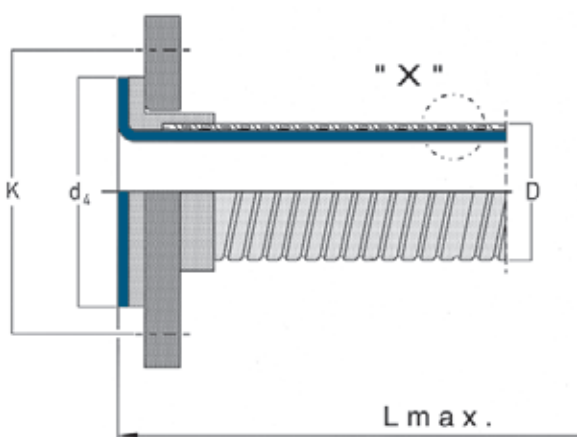

Detail „X“

DN	L <sub>max.</sub> (mm)	D (mm)	Bend-radius min. (mm)	Working-pressure max. 10 <sup>5</sup> Pa	d <sub>4</sub> (mm)	K (mm)	Screws	Weights	
								Hose (ca. kg/m)	Flange (ca. kg/side)
15	5000	19	325	10,0	45	65	4xM12	0,5	0,8
20	5000	23	350	10,0	58	75	4xM12	0,6	1,0
25	5000	28	350	10,0	68	85	4xM12	0,9	1,2
32	5000	35	400	10,0	78	100	4xM16	1,1	1,8
40	5000	45	550	10,0	88	110	4xM16	1,6	1,9
50	5000	55	750	10,0	102	125	4xM16	2,0	2,4
80	5000	87	1300	10,0	138	160	8xM16	5,0	3,6
100	5000	100	1500	7,5	158	180	8xM16	6,8	4,5

L = Length

D = External diameter

d<sub>4</sub> = Flaring diameter

K = Bolt circle

## PTFE chemical hose-smooth bore with annularly corrugating and wire braid (PN 10)

The annularly corrugated hose shows a multitude of self-contained and parallel metal convolutes in equal distance. The annularly corrugated hose has a braiding to increase the pressure resistance. It has a straight PTFE lining.



# PTFE chemical hose-smooth bore with annularly corrugating and wire braid (PN 10)

Lining-materials:

- PTFE (virgin or conductive)

Different lining thicknesses on request.

Flange design:

- fix-fix
- fix-loose
- loose-loose

Other pressure rates:

- PN 16
- PN 25
- PN 40

Material: carbon steel and stainless steel

Special features: earthing studs, earthing lugs, flange stopper, final painting.

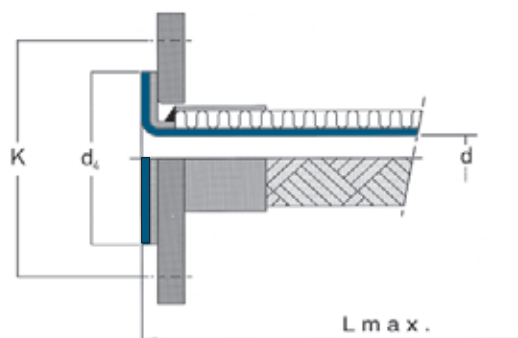

DN	L <sub>max.</sub> (mm)	d (mm)	Bend-radius min. (mm)	Working-pressure max. 10 <sup>5</sup> Pa	d <sub>4</sub> (mm)	K (mm)	Screws	Weights	
								Hose (ca. kg/m)	Flange (ca. kg/side)
25	5000	21	350	25	68	85	4 x M 12	0,8	1,2
32	5000	27	400	20	78	100	4 x M 16	1,0	1,7
40	5000	33	550	16	88	110	4 x M 16	1,6	1,9
50	5000	45	750	16	102	125	4 x M 16	1,6	2,4
65	5000	58	1000	14	122	145	4 x M 16	1,8	3,4
80	5000	73	1300	12	138	160	8 x M 16	2,6	3,8
100	5000	97	1500	10	158	180	8 x M 16	3,45	4,2
125	5000	120	1800	10	188	210	8 x M 16	5,8	5,2
150	5000	142	2000	10	212	240	8 x M 20	8,2	6,4
200	5000	192	2500	10	268	295	8 x M 20	11,0	7,8

L = Length  
D = External diameter  
d<sub>4</sub> = Flaring diameter  
K = Bolt circle

## PTFE-spiral tubing (PN 10)

The spiral-convoluted PTFE hose offers a high flexibility, but shows a low pressure resistance.

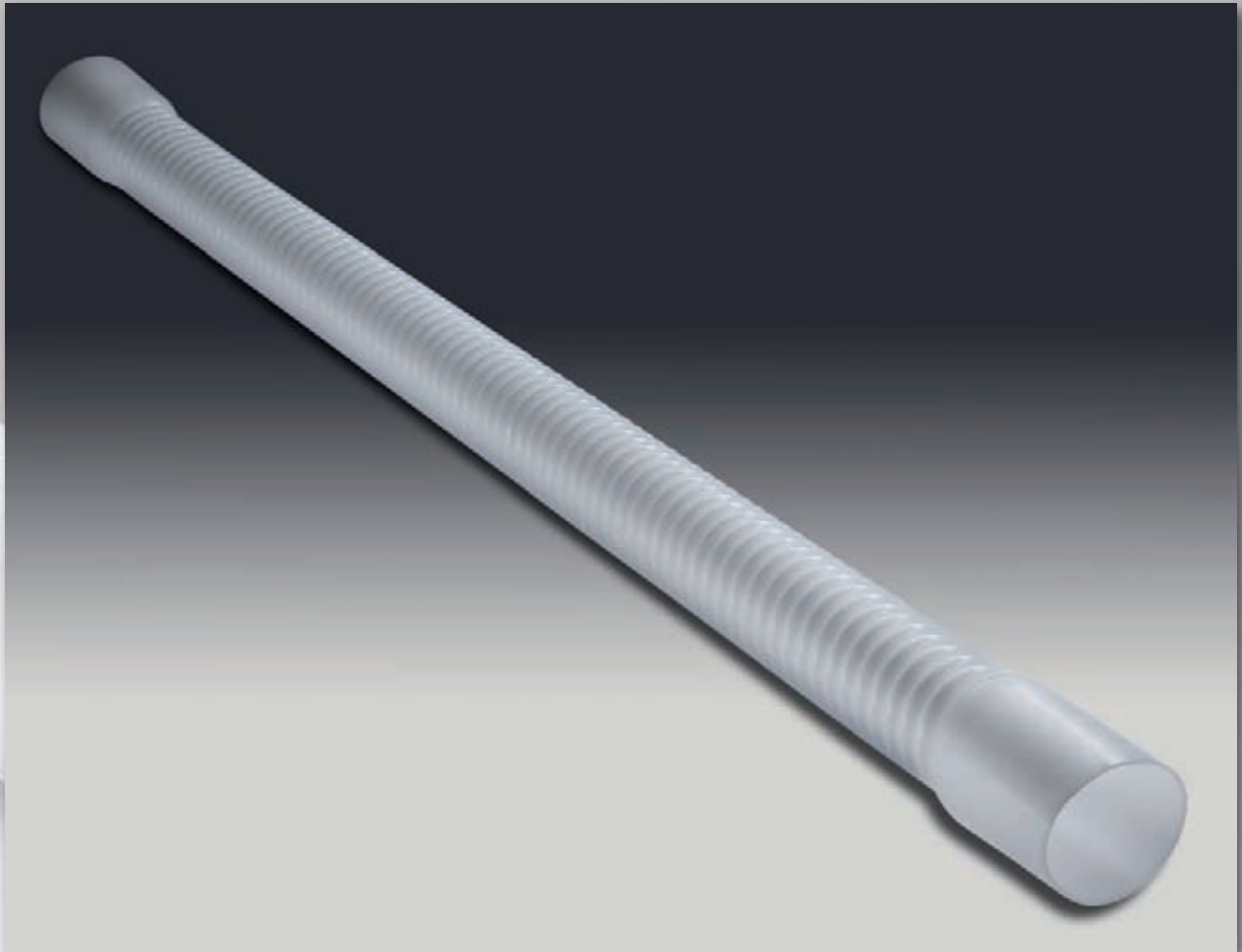

## PTFE-spiral tubing (PN 10)

Lining-materials:

- PTFE (virgin or conductive)

Other pressure rates:

- PN 16
- PN 25
- PN 40

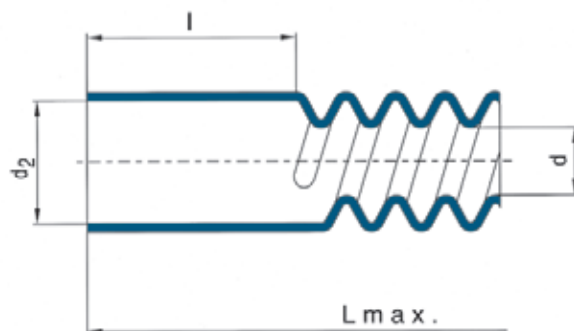

DN	l (mm)	L <sub>max.</sub> (mm)	d (mm)	d <sub>2</sub> (mm)	Bend- radius min. (mm)	Working- pressure max. 10 <sup>5</sup> Pa	Weights Hose (ca. kg/m)
15	50	5000	15	23	60	1,50	0,4
20	50	5000	19	30	60	1,50	0,5
25	50	5000	25	35	80	1,50	0,5
40	75	5000	38	48	110	1,25	0,6
50	75	5000	45	58	210	1,25	0,9
80	100	5000	70	90	400	1,25	1,8
100	100	5000	95	115	550	1,00	2,8

l = Cylindrical ending

L = Length

d = Internal diameter spiral tubing

d<sub>2</sub> = Internal diameter cylindrical

## PTFE-spiral tubing with flanges (PN 10)

The spiral-convoluted PTFE hose offers a high flexibility, but shows a low pressure resistance. The connection is done by means of crimped flanges.



## PTFE-spiral tubing with flanges (PN 10)

Lining-materials:

- PTFE (virgin or conductive)

Different lining thicknesses on request.

Flange design:

- loose-loose

Other pressure rates:

- PN 16
- PN 25
- PN 40

Material: carbon steel and stainless steel

Special features: earthing studs, final painting.

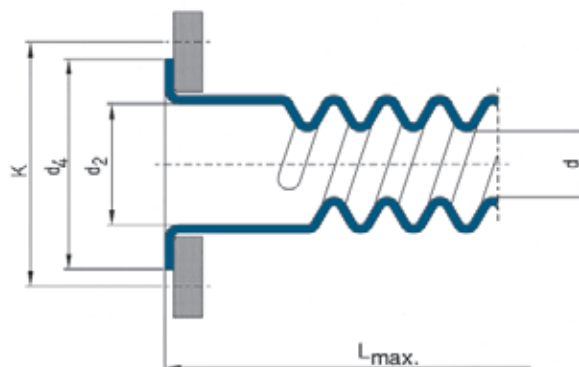

DN	L <sub>max.</sub> (mm)	d (mm)	d <sub>2</sub> (mm)	Bend-radius min. (mm)	Working- pressure max. 10 <sup>5</sup> Pa	d <sub>4</sub> (mm)	K (mm)	Screws	Weights	
									Hose (ca. kg/m)	Flange (ca. kg/side)
15	5000	15	23	60	1,50	45	65	4 x M 12	0,4	0,7
20	5000	19	30	60	1,50	58	75	4 x M 12	0,5	0,9
25	5000	25	35	80	1,50	68	85	4 x M 12	0,5	1,1
40	5000	38	48	110	1,25	88	110	4 x M 16	0,6	1,8
50	5000	45	58	210	1,25	102	125	4 x M 16	0,9	2,0
80	5000	70	90	400	1,25	138	160	8 x M 16	1,8	3,5
100	5000	95	115	550	1,00	158	180	8 x M 16	2,8	3,5

L = Length

d = Internal diameter spiral tubing

d<sub>2</sub> = Internal diameter cylindrical

d<sub>4</sub> = Flaring diameter

K = Bolt circle



## PTFE chemical transfer hose-spiral tube bore width stripwound hose (PN 10)

The PTFE corrugated hose combines high flexibility with a good pressure resistance. The braiding prevents an elongation in case of compression load and serves as protection as well as reinforcement of the PTFE hose.

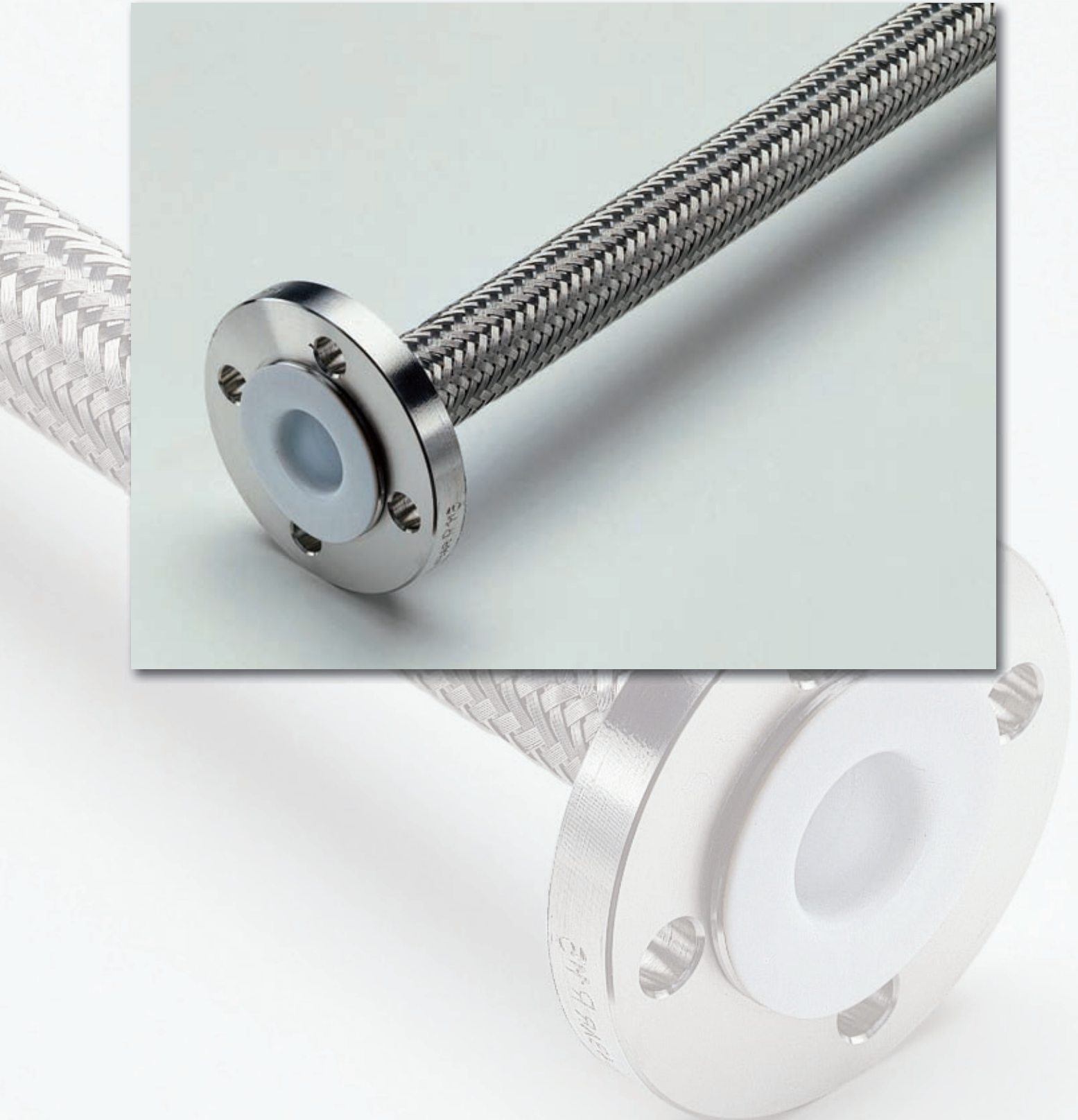

# PTFE chemical transfer hose-spiral tube bore width stripwound hose (PN 10)

Lining-materials:

- PTFE (virgin or conductive)

Different lining thicknesses on request.

Flange design:

- fix-fix
- fix-loose
- loose-loose

Other pressure rates:

- PN 16
- PN 25
- PN 40

Material: carbon steel and stainless steel

Special features: earthing studs, final painting.

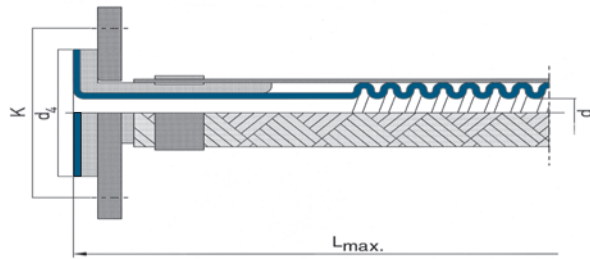

DN	L <sub>max.</sub> (mm)	d (mm)	Bend-radius min. (mm)	Working-pressure max. 10 <sup>5</sup> Pa	d <sub>1</sub> (mm)	K (mm)	Screws	Weights	
								Hose (ca. kg/m)	Flange (ca. kg/side)
15	5000	15	80	10	45	65	4 x M 12	0,6	0,7
20	5000	19	80	10	58	75	4 x M 12	0,9	1,0
25	5000	25	115	10	68	85	4 x M 12	1,0	1,1
40	5000	38	150	10	88	110	4 x M 16	1,3	2,0
50	5000	45	200	10	102	125	4 x M 16	1,8	2,3
80	5000	70	400	5	138	160	8 x M 16	3,5	3,5
100	5000	95	600	5	158	180	8 x M 16	4,6	4,0

l = Cylindrical ending

L = Length

d = Internal diameter spiral tubing

d<sub>2</sub> = Internal diameter cylindrical

## Auxiliary flanges (PN 10)

Suitable for our range of hoses, we offer specially shaped flanges for the protection of the hose lining.

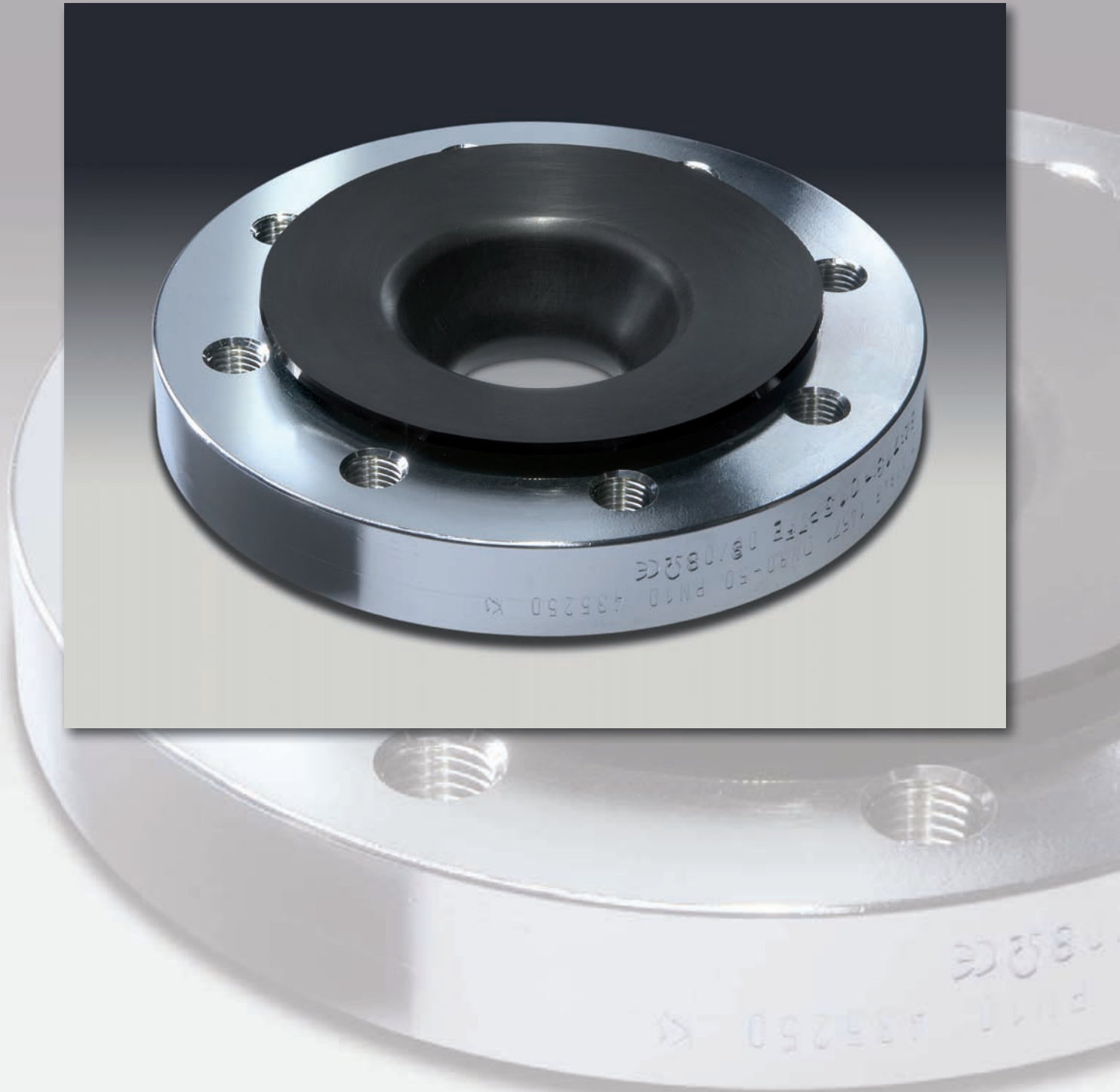

## Auxiliary flanges (PN 10)

Lining-materials:

- PTFE (virgin or conductive)

Different lining thicknesses on request.

Connections:

- up to diameter nominal DN 65:  
4 through hole or 2 x 4 threaded hole
- from diameter nominal DN 80:  
6 through hole or 2 x 6 threaded hole

Other pressure rates:

- PN 16
- PN 25
- PN 40

Material: carbon steel and stainless steel

Special features: earthing studs, earthing lugs, final painting.

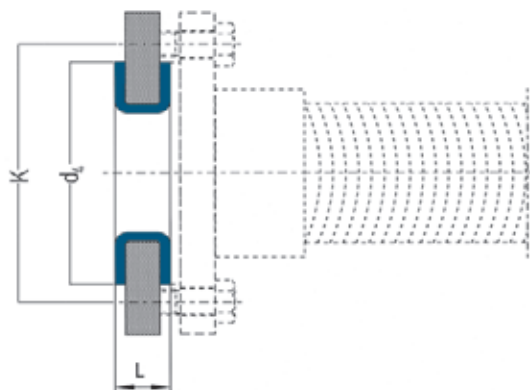

DN	L (mm)	Form	d <sub>4</sub> (mm)	K (mm)	Screws	Weights (ca. kg/piece)
15	16	indicate horse type	45	65	M 12	0,7
20	16		58	75	M 12	0,9
25	19		68	85	M 12	1,2
32	19		78	100	M 16	1,7
40	19		88	110	M 16	1,9
50	20		102	125	M 16	2,5
65	20		122	145	M 16	3,4
80	22		138	160	M 16	3,8
100	22		158	180	M 16	4,2

L = Total length

d<sub>4</sub> = Flaring diameter

K = Bolt circle

## Special parts

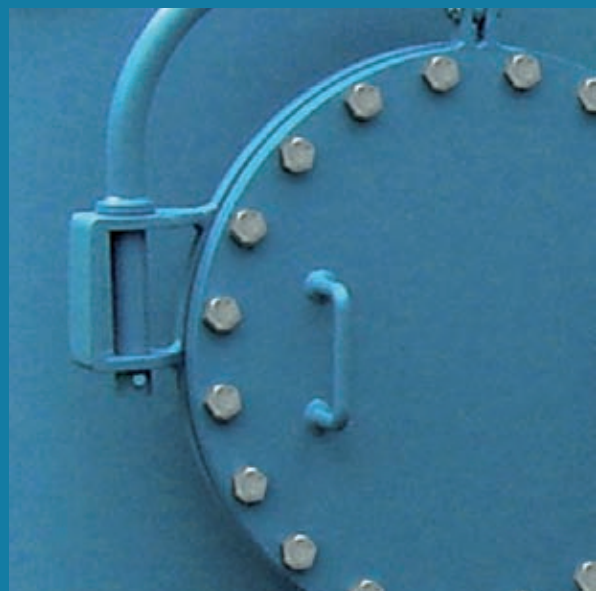

# Special parts

If you did not find the piping part you need in this catalogue, please contact us.

We also manufacture special forms or dimensions according to your requirements. Simply send us your technical drawing or a sketch and we will suggest a possible solution.

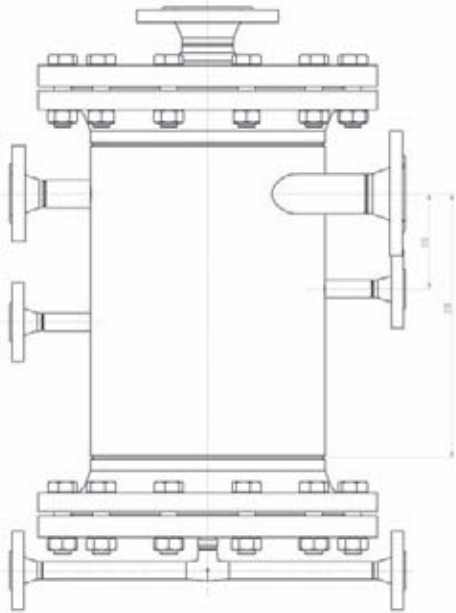
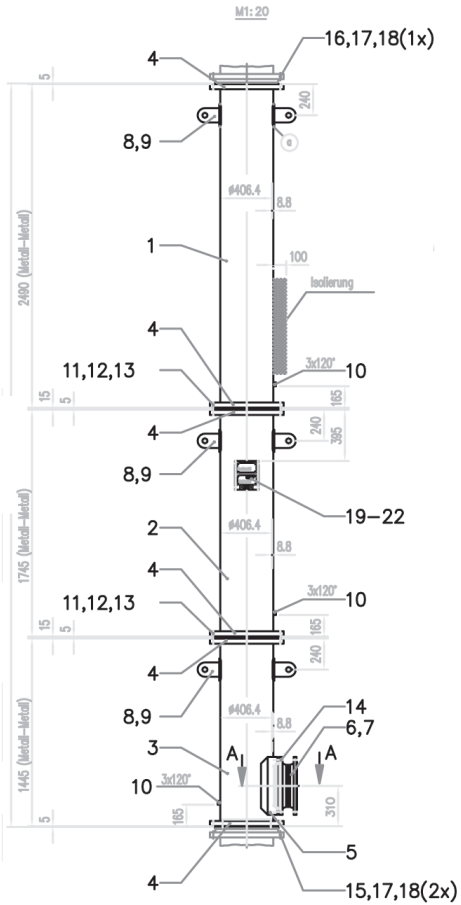

## Accessories





## Accessories

BAUM offers a comprehensive range of accessories for your piping systems, that include safety spray shields and star washers (contact rings).



## Accessories

### Star washer (contact rings)

Contact rings ensure electric contact and conductivity between the lap-joint flange and the stub-end, even though the surface of your piping parts have a final painting. Thus secure earthing is possible with protective finishing.

The contact rings are gripped between lap-joint flange and loose flange. The contacts of the rings breach the painting.

The contact rings are manufactured from spring steel and can be applied to the following nominal pipe sizes (DN):

DN	
DIN	ANSI
25	1"
32	1 1/4"
40	1 1/2"
50	2"
65	2 1/2"
80	3"
100	4"



### Safety spray shields

Many chemical plants are operated with highly-aggressive media which can cause environmental pollution or even injury as a result of personal contact. Our safety spray shields offer complete security.

We recommend that you consider safety spray shields for flange connections, expansion joints and valves.











TECHNICAL SPECIFICATIONS

# Technical Specifications

These specifications define the material, technical data, fitting instructions and quality checks for our PTFE/PFA or PP lined pipes and fittings. They are in accordance with the following standards: DIN 2874 for general requirements and DIN 2848 for dimensions.

## Contents

### 1. Materials

- 1.1 Steel parts
- 1.2 Lining
- 1.3 External coating

### 2. General technical data

- 2.1 Pressure Equipment Directive (97/23/EC)
- 2.2 Steel pipe dimensions
- 2.3 Flange connections
- 2.4 Weights
- 2.5 Liner thickness
- 2.6 Operating temperatures
- 2.7 Operating pressures
- 2.8 Vacuum resistance
- 2.9 Vent holes
- 2.10 Tolerances
- 2.11 Protective covers

### 3. Quality management

- 3.1 Welding
- 3.2 Materials certificates
- 3.3 Raw material checks
- 3.4 Visual and dimensional checks
- 3.5 Spark tests
- 3.6 Hydrostatic tests
- 3.7 Marking
- 3.8 Certificates

### 4. Fitting instructions

- 4.1 Protective covers
- 4.2 Gaskets
- 4.3 Torques
- 4.4 Welding operations
- 4.5 Vent holes
- 4.6 Permeation and diffusion

### 5. Chemical resistance

- 5.1 PTFE
- 5.2 PFA
- 5.3 PP

### 6. Product development



# 1. Materials

## 1.1 Steel parts

1.1.1 All steel pipe meets :

DIN 1626 - DIN 2458 bzw.  
DIN 1629 - DIN 2448  
DIN EN 10217

1.1.2 Flanges and stub ends comply with:

DIN EN 1092-1

1.1.3 Fittings comply with:

DIN 2609 - DIN 2606  
DIN 2605  
DIN EN 10253

## 1.2 Lining

1.2.1 PTFE

The lining is made from virgin PTFE (Polytetrafluorethylene) without any pigments - its colour is white.

The minimum physical data acc. to DIN 2874 as well as GKV-guidelines are:

Tensile strength	= 26 N/mm <sup>2</sup>
Elongation	= 275%
Specific gravity	= 2,14 - 2,2 g/cm <sup>3</sup>

1.2.2 PFA

The injected material is pure PFA (Perfluoralkoxy) without any pigments - the colour is white opaque. The physical data according to DIN 2874 is:

Tensile strength	= 21 N/mm <sup>2</sup>
Elongation	= 300%
Specific gravity	= 2,12 - 2,16 g/cm <sup>3</sup>

1.2.3 PP

All PP liner pipes (Polypropylene) are made of material Type II acc. to DIN 8078; they are grey (RAL 7032).  
Physical Data:

Tensile strength	= 26 N/mm <sup>2</sup>
Elongation	= 120%
Specific gravity	= 0,91 g/cm <sup>3</sup>

1.2.4 Conductive lining

Upon request the PTFE- and PFA-lining can also be manufactured as conductive lining. The colour is deep black.

The resistivity acc. DIN/EC 60093 and DIN/EC 60167 does not exceed 10<sup>8</sup> Ohm at any place.

1.2.5 FDA conformity

Upon customers' request the lining of our piping parts complies to the regulations of the Food and Drug Administration (FDA).

## 1.3 External Coating

1.3.1 Sandblasting

All carbon steel parts are sandblasted acc. to SA 2.5.

1.3.2 Paint coating

All PTFE-lined carbon steel products are painted with an epoxy-zinc-chromate primer to protect them from corrosion.

## 2. General technical data

### 2.1 Pressure Equipment Directive (PED 97/23/EC)

The piping parts are manufactured within the pressure equipment directive (PED). They fulfill all requirements of construction, manufacturing and testing. Upon request we can issue a declaration of conformity for modules A, A1 and G for the categories I to IV. We are also authorized to use the CE-marking.

### 2.2 Steel pipe dimensions

The outer pipe dimensions comply with DIN 2448 and DIN 2458 respectively. This also applies to the wall thickness as standard.

### 2.3 Flange connections

Flange connections comply with DIN 1092-1.

### 2.4 Weights of lined pipe and fittings

Please refer to the corresponding data sheets.

## 2. General technical data

### 2.5 Liner thickness

In accordance with DIN 2874 the lining thickness must be 3 mm min. In practice, however, thicker linings offer better safety under vacuum, better resistance against abrasion as well as lower gas permeability. As far as PTFE lining is concerned, diverse operating conditions require different liner thicknesses:

DN	Standard mm	Heavy duty mm
25	3	4
32	3	4
40	3	4
50	3	4
65	3	4
80	3	4
100	3	5
125	4,5	6
150	5	6
200	5	6
250	5	7,5
300	5	7,5

The liner thickness of fittings corresponds to the liner thickness of lined pipes. However, piping parts might have a greater liner thickness to optimise results. Other lining thickness can be manufactured upon customer demand.

### 2.6 Operating temperatures

Maximum operating temperatures are:

PTFE	230 °C
PFA	230 °C
PP	100 °C

These temperatures only apply under optimum conditions. Special conditions may require a reduction in vacuum and pressure.

### 2.7 Operating pressures

Standard piping parts can be delivered in

the pressure levels PN10, PN25 and PN40. Other operating pressures are available upon request.

### 2.8 Vacuum resistance

The vacuum resistance of the lined piping parts is determined by production, technology and liner thickness.

The optimisation of the liner thickness enables the following values for vacuum resistance:

**DN 25 to 80 = 0 PA up to 230 °C**

**DN 100 to 150 = 0 PA up to 180 °C**

**DN 200 to 250 = 0 PA up to 150°C**

**DN 300 = 0 PA up to 120 °C**

Based on your operating environment we can define the optimal liner thickness for your application.

### 2.9 Ventholes

Vent holes should be kept open at all times. They have a dual function. First, they allow any permeating gas should to escape, secondly, they serve as leakage indicators to ensure rapid repair.

### 2.10 Tolerances

Tolerances of pipe and fittings are defined acc. DIN 2448. The liner thickness may vary by 10%. Flared liner thickness may be up to 20% thinner due to the flaring process.

### 2.11 Protective covers

Flares are protected with a water proof plywood cover or plastic cap. All bolts and nuts are galvanized and can easily be loosened.

## 3. Quality management

### 3.1 Welding

Our welding processes are subject to the following criteria:

1. We are a recognised manufacturer in accordance with AD-Merkblatt HPO/TRD 201/DIN EN 729-2.
2. Our processes conform to AD-Merkblatt HP 2/1.
3. Our operations are supervised by a recognised welding expert.
4. We only employ welders with a HP 3 certificate.

### 3.2 Material certificates

All pipe, flanges, elbows and welded fittings are certified according to EN 10204 - 3.1.

### 3.3 Raw material checks

Lining materials are only procured with material certificates WAZ 2.2 from manufacturers certified acc. to ISO 9001.

### 3.4 Visual and dimensional checks

In addition, our own laboratory continually checks and records the physical data of semifinished products from the production line. The dimensions of all pipes and fittings are checked visually.

### 3.5 Sparktests

All non-conductive lined pipe and fittings undergo a 30.000 Volt spark test to make sure the lining is not porous.

### 3.6 Hydrostatic tests

The hydrostatic test is carried out at the 1.43-times of the nominal working pressure.

### 3.7 Marking

In accordance with DIN 2874, every pipe and fitting can be marked on the flange's circumference as follows:

Manufacturer's name  
Production lot  
Lining material  
Date of production  
CE marking (if applicable)

Additional markings – e.g. material no. – are available upon customer request.

### 3.8 Certificates

# 3. Quality management

## 3.8 Certificates



## 4. Fitting Instructions

### 4.1 Protective covers

Protective covers must only be removed immediately before fitting.

### 4.2 Gaskets

Flared surfaces of identical materials (PTFE/PFA) do not require gaskets. Gaskets are only needed for connections frequently undone or for connections to other materials such as metal, glass, enamel, etc. Lined pipes and fittings may not be welded, as the high temperature will destroy the plastic.

### 4.3 Torques (for PN10)

Torques for other pressure rates available upon request. When using smooth-running and greased screws and nuts we recommend the torques in the table below. The torque wrench should be used in a cross manner.

### 4.4 Welding operations

Lined pipes and fittings may not be welded, as the high temperature will destroy the plastic.

### 4.5 Vent holes

Vent holes should at all times be kept open. Care should be taken not to clog them with paint or insulating material.

### 4.6 Permeation and diffusion

The term permeation defines the transport of medium through the lining. Permeation is caused by two physical incidents: firstly, the diffusion of the medium through the spaces between the molecules of the plastic; secondly, the solubility of the medium in the polymer (absorption).

Diffusion can be decreased by the choice of suitable types of PTFE, by increasing the liner thickness and by using higher levels of crystallinity. However, this increases the risk of cracks caused by strain. To ensure optimal product safety all aspects have to be taken into consideration.

Absorption defines the diffusion of medium into the liner. Cyclical stress due to temperature or pressure leads to elongation mechanisms which cause aggregations of medium and even blisters. Isolation of those piping parts can avoid or reduce those effects considerably.

Diameter n. DN	Bolts PN 10	Torque Nm
25	4 x M 12	34
32	4 x M 16	55
40	4 x M 16	68
50	4 x M 16	86
65	4 x M 16	115
80	8 x M 16	71
100	8 x M 16	78
125	8 x M 16	105
150	8 x M 20	141
200	8 x M 20	208
250	12 x M 20	166
300	12 x M 20	197
350	16 x M 20	260
400	26 x M 24	330
500	20 x M 24	460

Details for assembly and operating instructions can be found in our data sheet FB 03.4b Assembly and operating instructions Rev.002-15.02.08.

## 5. Chemical Resistance

- 5.1 **PTFE** has a universal chemical resistance against almost all chemicals and solvents within its continuous operating temperature - with the exception of molten alkalis, elementary fluorine and certain halogenes
- 5.2 **PFA** identical with PTFE (5.1)
- 5.3 **PP** Please refer to the manufacturer's information.

## 6. Product development

This documentation is based on the experience we have gained up to now, it is intended to provide the user with advice.

All information is to the best of our knowledge and believed to be correct and given without responsibility.

We assume no liability with respect to the execution and nature of our products as well as their performance.

We reserve the right to make technical changes resulting from the further development of our products without giving prior notice.

Edition 2010