

**Steam Trap
Management
Products and Services**

Armstrong



Armstrong®

Intelligent System Solutions™

STEAM • AIR • HOT WATER

According to the Alliance to Save Energy, facilities have saved as much as 17% of fuel use when implementing energy-saving processes. Establishing a consistent, long-term steam trap management process is one way to achieve savings.

Historical Approach to Steam Trap Program*

Trap inspections are typically performed one time per year. The problem with this approach is that steam traps fail every day. These undetected failures lead to system irregularities, which, when left undetected long enough, can result in severe problems and equate to important financial losses.

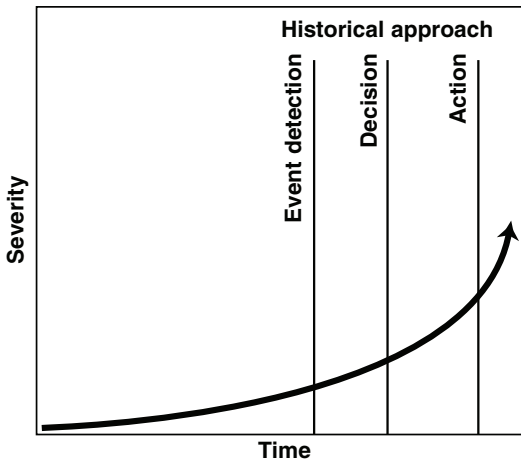

Proactive Approach to Best Practice Steam Trap Management*

Early detection means being able to act on a trap failure before the associated problem becomes severe. Therefore, immediate evaluation of the situation and measurement of the results are critical for continued best practice process improvement, yearly steam loss reductions and sustained monetary savings.

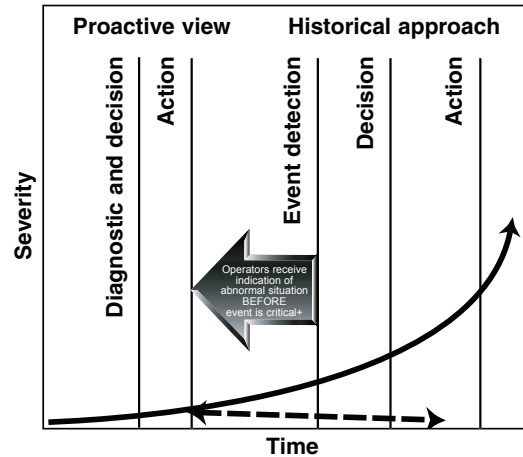

*Schavey, L. and Stout, J., «Achieving Operational Excellence in Gas Plants,» Hydrocarbon Processing, January 2005.

Wireless, Labor-free, Instant Notification of Steam Trap Failure!

If you were to describe your vision for steam trap best practice, what would it look like?

Awareness

- The ability to constantly monitor the steam trap population without labor allocation
- Instant notification of steam trap failure

Action

- Quick diagnosis and action on best trap replacement based on return on investment (ROI)

Accountability

- A reporting system that provides tracking, measurement, ROI analysis and easy company-wide communication.



SteamStar®

Company-wide awareness and measurement of steam trap performance for ROI decision making.

SteamStar® Easy-to-use and Very Affordable Steam Trap Software



SteamStar® is the first Web-based software for recording, monitoring and managing steam trap information.

**SteamStar Web-based software can...
Improve steam system efficiency.**

Steam system efficiency can be directly linked to how well the system is managed. SteamStar provides diagnostic reporting at various levels of organizational responsibility. The reports permit the evaluation of current conditions and provide the knowledge necessary to make money- saving decisions.

Achieve best practice energy management goals.

History has shown that companies maximize sustainable cost savings when energy goals are measured, monitored, and managed on a consistent basis. SteamStar is the Web-based tool that will bring data together by site, by region and by company to help achieve best practice energy management goals.

Save valuable time.

Typically steam trap data are presented from multiple sites in different software formats and with different qualifying terminology. These variables make managing steam system information difficult and time-consuming. SteamStar offers a platform for company-wide steam data to be viewed and analyzed without wasted time.

Eliminate costs associated with software.

licensing agreements. Licensing agreements can cost tens of thousands of euro for initial software purchase. For the software to facilitate multiple users, additional capital outlay is required. The Web-based platform of SteamStar eliminates licensing fees and dramatically reduces the required investment. A one month return on investment!

Improve company-wide communication.

Users at the plant level can perform evaluations to determine root causes of steam system issues. Using the same platform, the global energy manager has the ability to analyze data for sites around the world. This level of communication promotes understanding of steam system efficiency.

Steam Trap Management

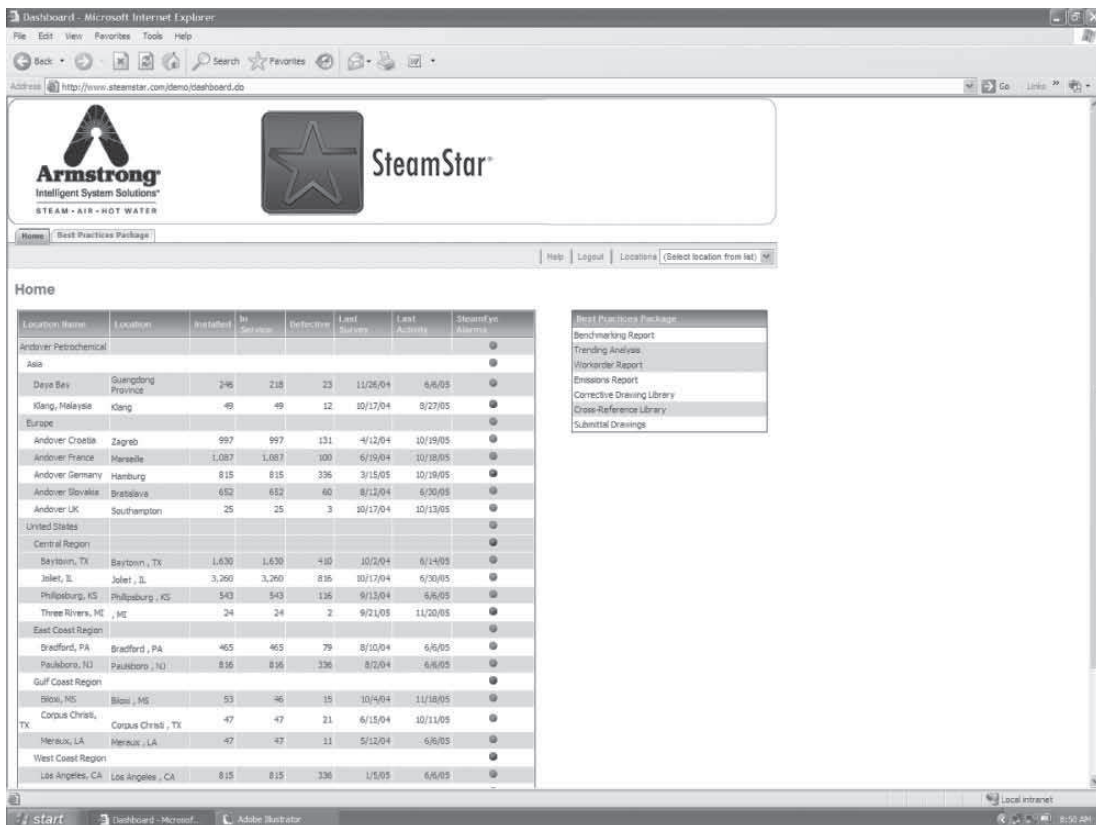

Screen shot of SteamStar home page.



SteamStar®

Easy-to-use and Very Affordable Steam Trap Software

SteamStar® Web-based software will evaluate steam system data.

Continuous Steam Trap Monitoring captures real time steam trap operation. Information is translated by SteamStar into actionable reports. All of the reports available in SteamStar are designed for best practice measurement.

- Executive Summary
- Steam and Monetary Loss
- Defective Trap Report
- Manufacturer Summary
- Trap Evaluation by Application

Company Benchmarking

This premium report establishes a comparison to sister sites and industry peer best practices. The user has a choice of which sites to benchmark and which factors to compare. Steam losses and monetary losses can be compared by site, by type of application, by type of trap, and more. This report will offer management a wide analysis of which sites are working to reduce steam losses and which lag behind. It will also highlight any areas of concern in terms of high steam trap failure rate compared to total monetary losses. This report is a valuable tool for facility managers and global energy managers alike.

Prioritized Work Orders

The work order report is a premium report that was designed for optimum facility payback on labor and material while keeping energy losses to a minimum. This report is available at the site or unit level and will create a work order for steam trap repairs based on payback.

Trend History

The premium trend analysis report will assist a manager with the comparison of multiple years of data. The data available for comparison are steam loss, monetary loss, fuel consumed, and emissions created. Like the other premium reports, the trend analysis report can be compared by site and/or region. It will also track emissions – CO₂, SO_x, NO_x – and highlight the progress made toward steam system efficiency and dollars saved.

Emissions Summary

The premium emissions report is valuable for its ability to focus on the quantifiable emissions of CO₂, SO_x, and NO_x in one summarized view. Steam system efficiency is not only viewed as important in terms of energy losses but also in terms of environmental impact. The emissions report is especially beneficial to users that are penalized by world governments for high emission factors.

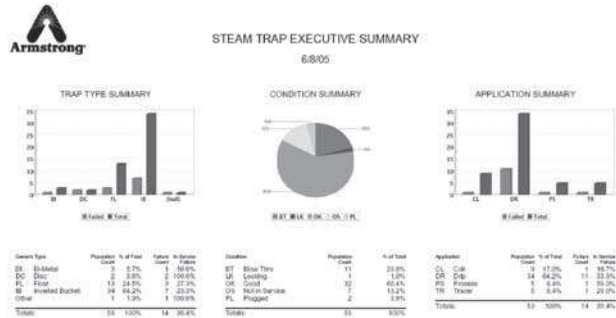

Screen shot of executive summary.

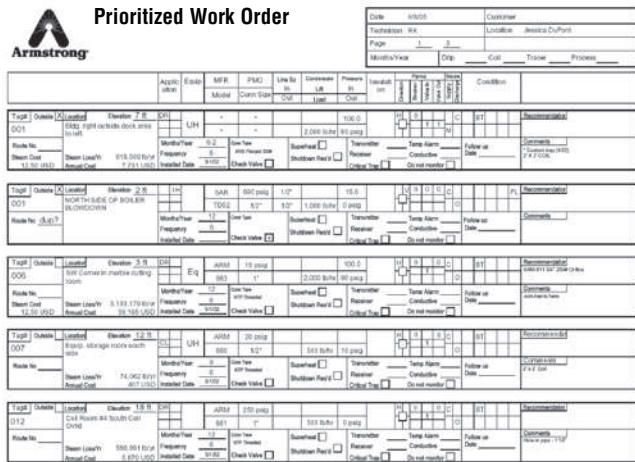

Screen shot of prioritized work order.

Upload your current steam trap information easily, regardless of current format!

Notes



A large area of the page is filled with horizontal dotted lines, providing space for handwritten notes.

Steam Trap Management

Three Challenges - One System Solution

Three constant challenges that plant managers and maintenance personnel face in the operation of any system include:

- Identifying a failure - ability to immediately pinpoint what has failed, when it failed and where it failed.
- Evaluating the scope - comprehending the magnitude of the failure especially in terms of energy lost and emissions discharged to the atmosphere.
- Measuring the impact - accurately calculate the costs including wasted energy, process disruptions and plant shutdowns, safety hazards and fines levied.

AIM enables your team to tackle all three challenges with one system solution that combines a mix of methods including acoustic and temperature monitoring with integrated software through a smart wireless gateway to deliver:

- Immediate failure notification of devices such as steam traps
- Immediate notification of release to flare for emissions mitigation
- Pinpoint accuracy of failure location for fast resource deployment
- Detection of “sizzling” relief valves for proactive maintenance scheduling
- Preemptive warning of hazardous vapor release to improve worker safety

Steam Trap Management



TD5100 Temperature Monitoring

The Armstrong Intelligent Monitoring Model TD5100 is a temperature monitoring solution that allows you to tackle critical temperature problems. The AIM® TD5100 can wirelessly monitor the skin temperature of any pipe, vessel or piece of equipment. Using non-intrusive technology combined with WirelessHART, the AIM® TD5100 is the ideal solution for any temporary or permanent 24/7 temperature monitoring.

ST5700 Steam Trap Monitoring

Armstrong Intelligent Monitoring Model ST5700 is a wireless monitoring technology that efficiently monitors and evaluates steam trap operation. The AIM® ST5700 identifies the conditions of a steam trap to determine significant problems that could put your operation at risk. The AIM® ST5700 can accurately detect potential issues such as plugged and blow thru steam traps which can result in a range of issues from failed equipment, to loss of product, to safety concerns. Immediate failure notification from the AIM® ST5700 helps identify the root cause while you minimize production losses and reduce energy consumption. Using non-intrusive technology combined with WirelessHART, the AIM® ST5700 is the ideal solution for any temporary or permanent 24/7 steam trap monitoring.



AD5000 Acoustic Monitoring

Armstrong Intelligent Monitoring Model AD5000 is a wireless monitoring technology designed to monitor acoustic patterns associated with leaking gasses and high pressure fluids. The AIM® AD5000 is the ideal solution to identify leaking isolation or safety relief valves. Identifying the source quickly can reduce the use of flare to burn off product and the costly fines that may be associated with it. Instant notification helps to minimize material and production loss.

Ultimately, the AD5000 can help cut down on environmental fines, reduce product recirculation and improve safety by instantly identifying the leak source. Using non-intrusive technology combined with WirelessHART, the AIM® AD5000 is the ideal solution for any temporary or permanent 24/7 acoustic monitoring.

All dimensions and weights are approximate. Use certified print for exact dimensions. Design and materials are subject to change without notice.

**Models AD500,
 ST5700 and
 TD5100
 without display
 screen**

mm

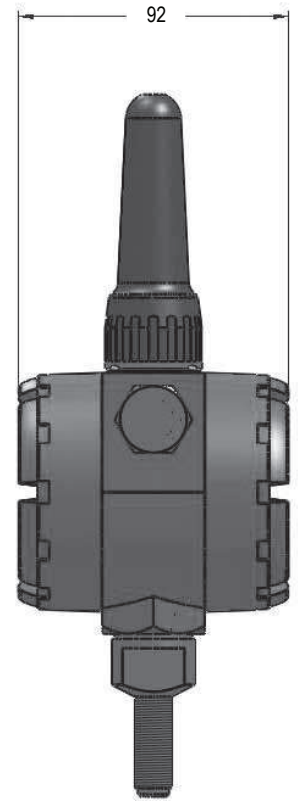
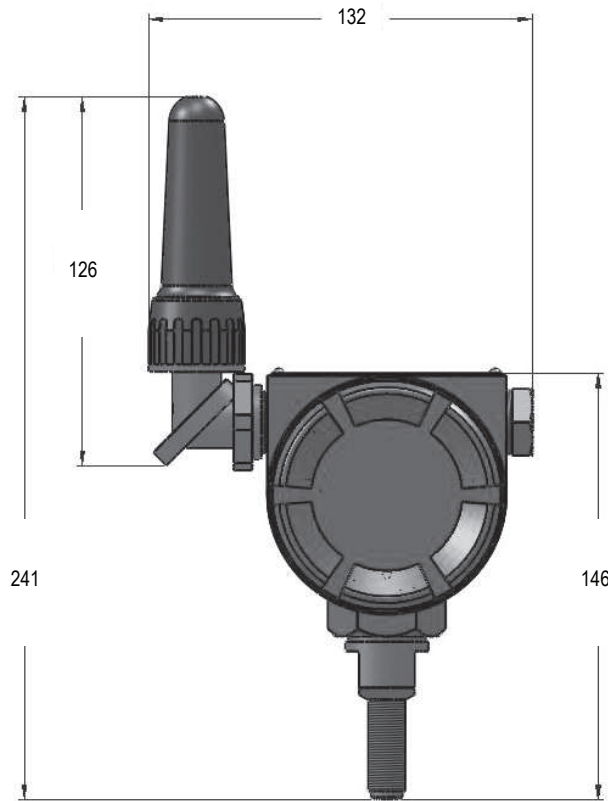

**Models AD500,
 ST5700 and
 TD5100
 with display
 screen**

mm

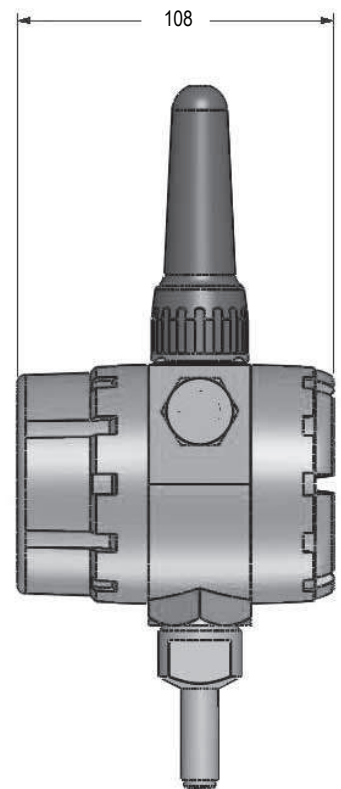
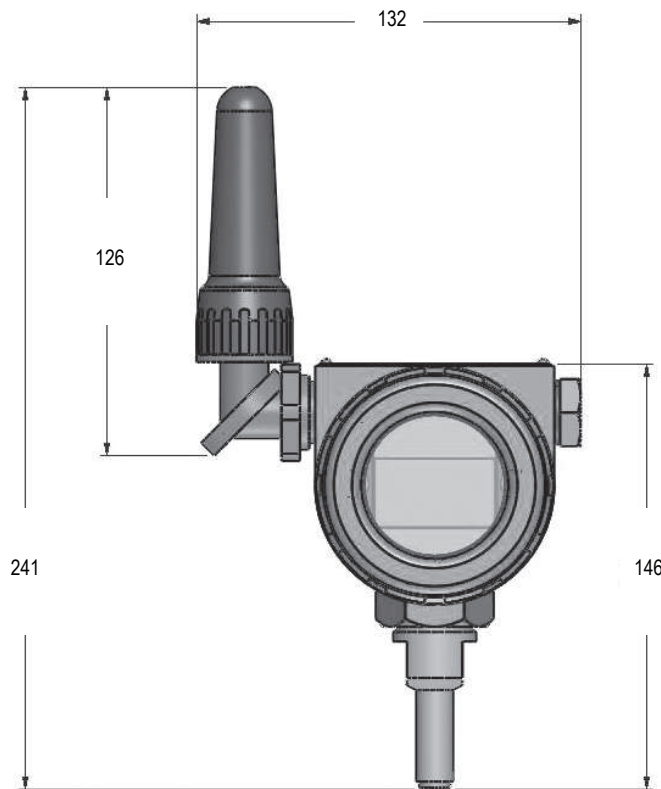

All dimensions and weights are approximate. Use certified print for exact dimensions. Design and materials are subject to change without notice.

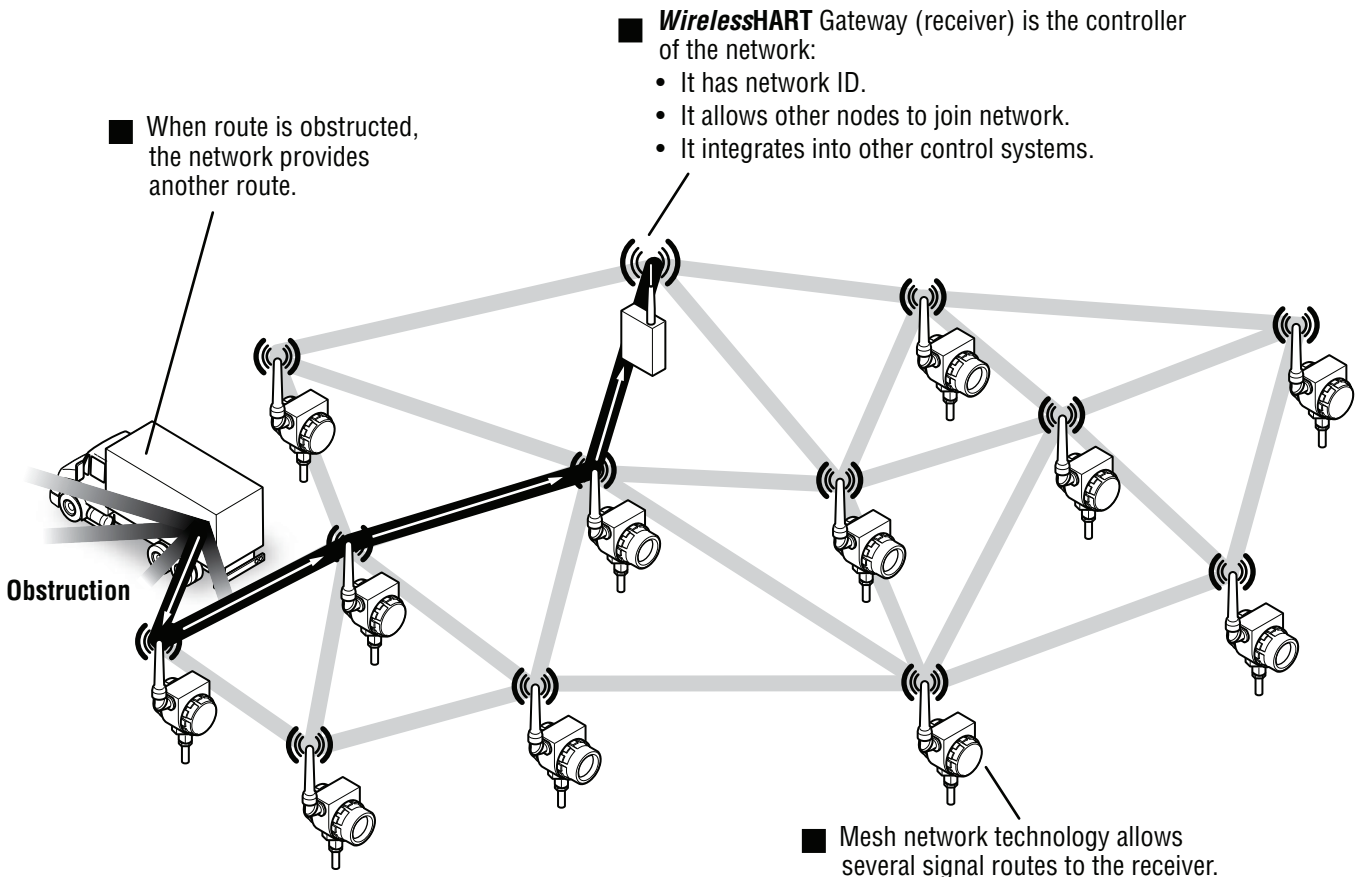

Self Organizing.

- Devices automatically establish routes for efficient and reliable communication.
- Expansion is simple... additional devices seamlessly integrate into existing networks.
- Mesh topology allows for easy network reconfiguration.

Self Healing.

- If obstructions are introduced within an existing network, the system will automatically adjust communication paths for continuous and reliable data flow.

Industry Standard IEEE 802.15.4.

- 2.4 GHz 16 band.
- Continuously hops across 16 channels to reduce potential interference.

No Blind Spots.

- Utilizing industry standard *WirelessHART™*, an open mesh networking design, AIM™ communicates through and around stacks, silos, cranes and other obstructions.

Harsh Environments? No Worries.

- AIM™ is designed to withstand extreme ambient temperature conditions (-40°F - 194°F) (-40°C - 90°C).

No Plant Disruptions.

- Installing AIM™ won't disrupt plant processes. There's no shutdown required to perform an installation and AIM is non-intrusive to valves, pipes and system equipment.

All dimensions and weights are approximate. Use certified print for exact dimensions. Design and materials are subject to change without notice.

Armstrong Intelligent Monitoring

The HART Communication Protocol has served as the world's leading process communication technology for smart instruments since 1989. Today, more than 30 million HART devices are installed and in service worldwide.

Industry suppliers are manufacturing and shipping HART products in record numbers—75% of the smart devices installed are HART-enabled.

More HART products are installed in more plants around the world than any other. No other communication protocol comes close.

Wireless technology allows users to access the vast amount of unused information stranded in these installed HART smart devices— 85% of the installed HART devices. It also provides a cost-effective, simple and reliable way to deploy new points of measurement and control without the wiring costs.

Simple

- Reduced installation and wiring costs
- Always on security
- Adjusts as new instruments are added and to changes in plant infrastructure

Reliable

- “Hops” across channels
- Co-existence with other wireless networks
- Optimizes bandwidth and radio time
- Mesh network and multiple access points

Secure

- Protects valuable information with multi-layered security
- Robust multi-tiered always on security
- Protects wireless network with channel hopping
- Reports message integrity failures and authentication failures

Item	Description
Based on Industrial Standards	HART - IEC 61158 <i>WirelessHART</i> - IEC/PAS 62591Ed.1 EDDL - IEC 61804-3 Radio & MAC - IEEE 802.15.4(TM)-2006 IEC/PA
Radio Standard	IEEE 802.15.4-2006 @ 250kbps
Frequency Band	2.4GHz
Frequency Management	Channel hopping on a per packet basis
Distance	Up to 250 m (820 ft) line-of-sight between devices
Power	Battery
Topologies	<i>WirelessHART</i> Mesh

All dimensions and weights are approximate. Use certified print for exact dimensions. Design and materials are subject to change without notice.



AIM[®]

Armstrong Intelligent Monitoring

Steam Trap Management

Factory Mutual (FM) Approval		
<i>United States</i>	Intrinsic Safe for Class I/II/III, Division 1, Groups A, B, C, D, E, F, and G Zone Rating: Zone 0, AEx ia IIC Temperature Code: T3 Ambient Temperature Range: T _{amb} -40°C to 90°C (-40°F to 194°F) For use with TADIRAN model TLH-5920 lithium ion battery only Standards used for Certification: FM3600, FM3610, FM3810, ANSI/ISA 60079-0, ANSI/ISA 60079-11	
<i>Canada</i>	Intrinsic Safe for Class I/II/III, Division 1, Groups A, B, C, D, E, F, and G Zone Rating: Zone 0, Ex ia IIC Temperature Code: T3 Ambient Temperature Range: T _{amb} -40°C to 90°C (-40°F to 194°F) For use with TADIRAN model TLH-5920 lithium ion battery only Standards used for Certification: CSA 1010.1, CSAC22.2No.157, CSAC22.2No.25,CAN/CSAE60079-0, CAN/CSA60079-11	
<i>European Certification</i>	ATEX Intrinsic Safety Ex ia IIC T3 Ambient Temperature Range: T _{amb} -40°C to 90°C (-40°F to 194°F) For use with TADIRAN model TLH-5920 lithium ion battery only Standards used for Certification: EN60079-0,EN60079-11, EN 60079-26	
<i>IECEX Certification</i>	Equipment Protection Level: Ga Gas/Vapour: EX ia IIC T3 Ambient Temperature Range: T _{amb} -40°C to 90°C (-40°F to 194°F) For use with TADIRAN model TLH-5920 lithium ion battery only Standards used for Certification: IEC 60079-0, IEC 60079-11, IEC 60079-26	

Output	<i>Wireless</i> HART 2.4 GHz
Local Display (if applicable)	Liquid Crystal Display Viewing Area: 34 mm x 14 mm (1.34" x 0.55")
Temperature Operating Range	With display: -30°C to 80°C (-22°F to 176°F) Without display: -40°C to 90°C (-40°F to 194°F)
Materials of Construction	Housing – Aluminum Paint – Powder Coat O-ring – Nitrile Stem – 304 SS Antenna – Nylon 6,6 Nampelate – 304 SS
Battery Type	Tadiran Lithium Ion Model – TLH-5920
Weight	1 Kg (2.2 lbs)
ST5700 Note: For proper operation, node must be installed on a steam trap operating at no less than 1 bar.	

All dimensions and weights are approximate. Use certified print for exact dimensions. Design and materials are subject to change without notice.



History

Industries use approximately 42% of the total energy consumed annually in Europe. Of this, about half (or 21% of total European energy consumption) is used to generate steam in more than 54,000 large industrial-sized boilers.

Unfortunately, much of that steam is lost through leaks in the distribution system, including piping, valves and steam traps. Lost steam must be replaced, which can only be done in a boiler that consumes fuel.

The cost of replacing wasted steam can be enormous in terms of system efficiency, lost production, fuel consumption, makeup water treatment cost, and maintenance. These additional costs must be factored into the bottom line of every organization.

Environmental Considerations

Inadequate trapping on steam mains not only results in economic losses, it also creates environmental concerns as additional fuel is burned to replace lost steam. For example, assume the steam-main pressure is 10 barg and the leak size is 5/64" – about the thickness of a coin. In this instance, approximately 12 kg of steam will be wasted per hour – escaping from the system or blowing through a trap and into the return line.

Twelve kilograms per hour may not sound significant, but over one year (8,400 hours), that small leak will waste the following equivalent amounts for fuel:

- 1.9 tons of bituminous coal at a value of €679 (coal cost €57/ton)
- 9 000 l of residual oil at a value of €978 (oil cost 0,11€/l)
- 89 m³ of natural gas at a value of €1,272 (gas cost €14,30/m³)

Pulverized bituminous coal in a dry bottom-firing boiler will generate the following pollutants per year:

- 330 kg of particulate matter
- 211 kg of sulfur oxides
- 114 kg of nitrogen oxides
- 3,3 kg of carbon monoxide
- 4 400 kg of total carbon

These figures represent a case in which just one trap has blown through – typical failure mode of many steam traps. Compound the figures by the number of potential failed traps and you can begin to understand the value of trap maintenance, both in terms of energy and the extra load placed on your environmental cleanup systems.

Evaluation = Efficiency = Dividend

Reliable evaluation of steam trap operation is necessary for traps to work at peak efficiency. Trap testing is a key element in a complete energy management program, and an essential skill for protecting your investment.

Accurately evaluating steam trap operation can pay dividends in energy conservation, save countless maintenance hours, and reduce unscheduled downtime caused by trap failure.

Steam-Trap Survey

To ensure that your steam traps are maximizing the return on your product investment, your first steps should be to conduct a steam-trap audit or trap survey, then implement a comprehensive trap-maintenance program. Proper trap maintenance requires someone who knows how each type of trap functions and can determine if each trap is operating as required.

Armstrong has the ability and trained personnel to conduct steam system energy audits for any facilities in the world. Our factory-trained technicians have decades of experience and have tested tens of millions of steam traps worldwide.

Test and Replace Just the Failed Traps

The sooner a trap is identified as an energy waster, the sooner it can be replaced. Since newer testing methods require minimal labor, traps can be tested more frequently and failed traps can quickly be identified. In addition, perfectly good traps that may be misdiagnosed as failed by less reliable testing techniques will no longer be routinely replaced, thus saving the expense of a new trap and related labor costs.

Armstrong continues to lead the industry with innovative testing and tracking tools such as SteamStar®, AIM® and TrapAlert™.

By using AIM technology, you can better spend your maintenance time repairing only defective traps and not evaluating traps that have been misdiagnosed as failed. In conjunction with SteamStar, the system becomes the premier steam trap management package for maintaining a healthy steam system.

Maintaining the Boiler Plant

Boiler plant reliability and efficiency depend on the stability and success of each component of the steam generation, distribution and condensate return system. Maintaining a boiler plant means paying close attention to components including flanges, elbows, valves, unions and steam traps, since each component has the potential to waste steam.

We can help with proper system evaluations, as well as piping recommendations, replacement-trap sizing and troubleshooting.

